



DREXEL UNIVERSITY

A PLAN FOR THE PUBLIC REALM

UNIVERSITY CITY CAMPUS

PREPARED FOR DREXEL UNIVERSITY

DREXEL UNIVERSITY
3141 Chestnut Street
Philadelphia, PA, 19104

PRODUCED BY WEST 8

WEST 8 URBAN DESIGN & LANDSCAPE ARCHITECTURE P.C.
333 Hudson Street
Suite 905
New York, NY 10013
1: 212 285 0088

NOVEMBER 2016

DREXEL UNIVERSITY: PUBLIC REALM PLAN

TABLE OF CONTENTS

7	INTRODUCTION
11	COMPOSITION OF THE CURRENT CAMPUS
25	A VISION FOR A COHERENT PUBLIC REALM
29	PUBLIC REALM COMPONENTS
31	STREETSCAPES
47	PUBLIC SPACES
77	SYSTEMS
101	EVENTS AND PROGRAMS
107	NEXT STEPS
117	ACKNOWLEDGMENTS



DREXEL'S CAMPUS FROM PERELMAN PLAZA

INTRODUCTION

The Drexel University Public Realm Plan is a landmark document that extends the University City campus environment from the classroom into shared landscapes, streets and walkways. The Plan identifies ways to coalesce Drexel's physical and cultural urban environment into a cohesive public realm.

The Plan builds on the four major principles of the University's 2012 Campus Master Plan:

- Distinguish Drexel as a vibrant urban university district.
- Bring the campus to the street.
- Draw the community around shared places.
- Expand the innovation district.

The West 8 Design team worked to analyze current conditions, generate feedback from stakeholders and Drexel community members, and create scenarios for the design and articulation of Drexel's open spaces, walkways, connections, and identity. In

addition, the team investigated practical and tangible design issues such as operations and maintenance, capital costs, and phasing.

The Plan is a tool for University leaders, planners, and personnel to envision the potential of their campus in a new way and work towards implementing changes in terms of large and small scale projects. The Plan is composed of three major parts:

- A Coherent Public Realm (Chapter 2). This describes a long-term (40-plus year) Vision for the transformation of the entire University City campus.
- Public Realm Components (Chapter 3). This distills the Vision into key public realm elements: streetscapes, public spaces, and systems.
- Events and Programming (Chapter 4). This describes the opportunities of campus life activities

that can help activate the new public realm vision. The last chapter of the document lays out priorities that can be used for capital planning and fund raising.



PLANNING PROCESS

Planning for an urban campus at the center of a densely populated city requires attention to the mitigation of scale, the impact of environmental conditions, the types of social practices and the features which establish identity.

To better understand the complex interrelationship of the urban design issues that challenge the existing campus, the project team undertook an extensive campus analysis in which each system of the campus framework was studied. Systems studies included circulation and traffic, safety, stormwater, open space, urban design, and lighting. The team observed ways in which students and others used the campus, and studied the interface between buildings, streets, and landscapes.

The design team became deeply immersed in not only the physical conditions of the campus, but also the social milieu of the Drexel community. Over the course of eight months, the project team conducted interviews with students, faculty, staff, and other stakeholders. The design team analyzed the feedback they received and used it to develop specific design guidelines for a cohesive Public Realm Plan.

West 8 also hosted a Drexel community open house in the lobby of Daskalakis Recreation Center; students, faculty, and staff were invited to visit and review a series of presentation boards in an open format. The design team presented options to gain an understanding of preferences regarding overarching priorities as well as for elements such as water features, gathering spaces, and public programming. Attendees shared feedback through notes and dialogue with the design team. The design

boards were also available online for viewing and comment following the event.

Planning for the Public Realm was also coordinated with ongoing plans for the former University City High School site, a joint venture between Drexel and Wexford Science + Technology; the 30th Street Station District Plan developed with Amtrak, SEPTA, Brandywine Realty, Drexel and eight other stakeholders; and Schuylkill Yards, a collaboration between Drexel and master developer Brandywine Realty Trust to create a new innovation neighborhood.



MEETING WITH STUDENTS AT OPEN HOUSE



PUBLIC REALM PLAN STUDY AREA

1

COMPOSITION OF THE CURRENT CAMPUS

Drexel University's University City campus includes 98 acres inextricably linked with the Philadelphia urban realm. Its verdant quads are the bustling streets and its bell tower is the city skyline. Drexel's student body is diverse, owing in part to its cooperative education program, a learning model that is one of the University's distinguishing features. Since its founding in 1891, Drexel has been an institution focused on innovation to suit the needs of a rapidly changing society and economy. Over 25,000 students and 5,000 faculty and staff come to Drexel to learn, teach and work, but also to be a part of this unique urban community.

Today, colleges and universities across the United States are recognizing the importance of a well-designed and vibrant public realm. Drexel's commitment to its truly urban identity is reflected in one of the underlying principles of its 2012 Campus Plan to "bring the campus to the street."

The traditional university models of idyllic Jeffersonian campuses, with walled perimeters, verdant quads, and single-use education buildings were of an age when resources like land and energy were bountiful and those with certain cultural and financial means were privileged enough to attend. Today, our world is delightfully more complex in terms of who is interested in attending universities—old, young, employed, single parents, those living in homes with multi-generations, culturally blended, multiple races, multi-classes, part-time workers, etc. These students require flexibility. They embrace diversity. Many find urban universities like Drexel a great fit.

How can Drexel's University City campus become more positively urban – greener, more amenable, and more vibrant? The potential for transformation at Drexel University is huge: of the 98 total acres of Drexel's University City campus, only 40% is building footprints, leaving over 58 acres of spaces and places to learn, interact, play, and relax.

A CAMPUS IN THE CITY

When Drexel was founded in West Philadelphia in 1891, Philadelphia was one of the largest, most dense cities in the nation with a bustling, vibrant, and diverse city life. Philadelphia has always been a city where ideas and public space converge, since the first public reading on July 8, 1776 of the Declaration of Independence on the State House Yard at what is now known as Independence Hall. Today, Philadelphia is rising as a hub for innovation, technology, and economic growth. Anchored by some of the best research hospitals, institutions of higher learning, and media and technology companies, Philadelphia is also attracting a growing number of energetic start-ups and tech companies. As such, Drexel University's entrepreneurial ethos of research, innovation, and cooperative education fits squarely within the economic and social culture of Philadelphia.

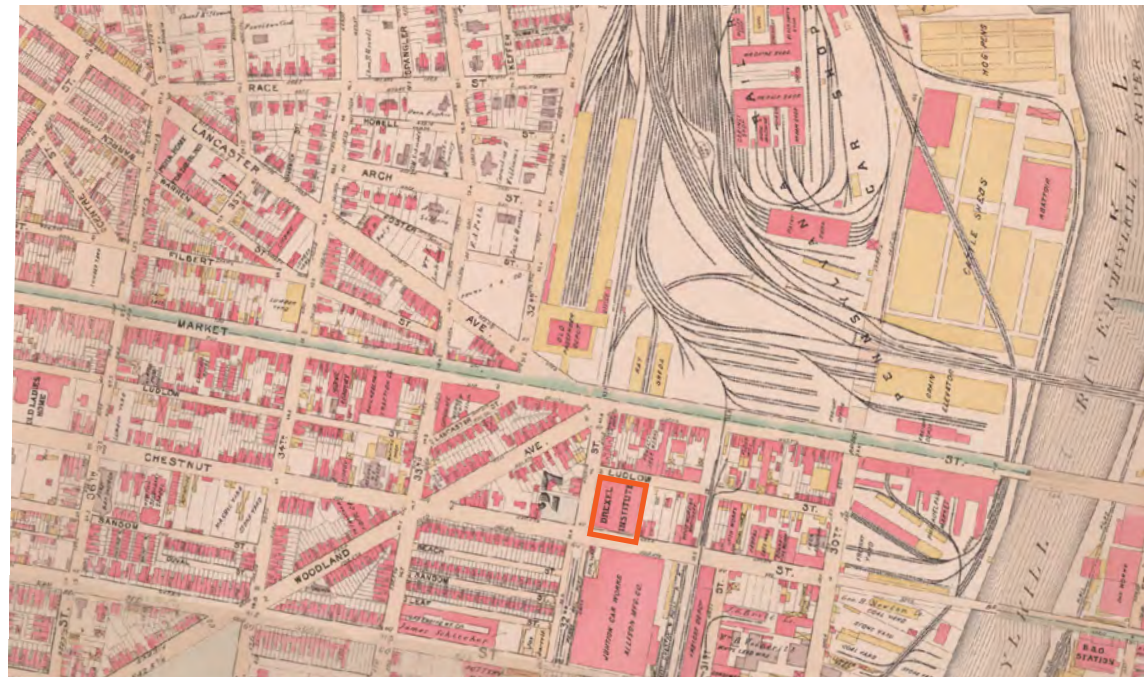

HISTORIC PLAN OF DREXEL'S NEIGHBORHOOD 1895

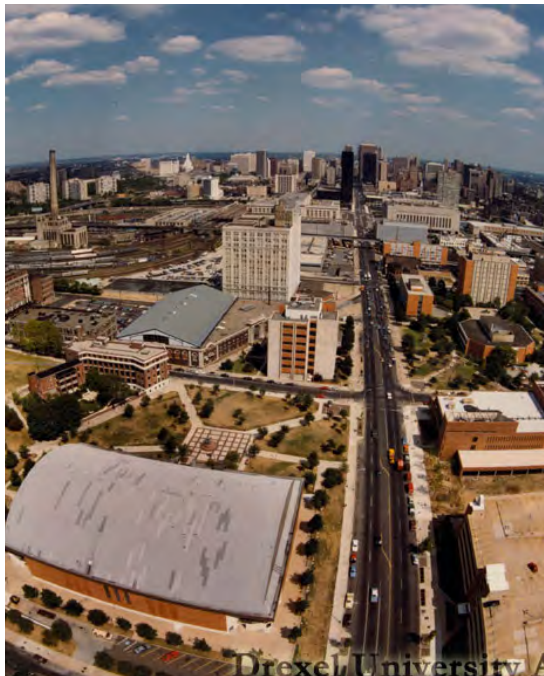

DREXEL CAMPUS, 1960'S

NEIGHBORHOOD CONTEXT

The campus was always immersed in City life. Early maps and plans show West Philadelphia's grid system, the significance of Market Street and key diagonal roads of Lancaster Avenue and others that reached out to the area's rural villages. Today, Drexel's neighborhood is called University City which includes, among others, the adjacent residential neighborhoods of Powelton Village and Mantua.

Over time, as Drexel expanded, the historic street and block pattern of the neighborhood was consolidated into superblocks, and larger, multi-story education buildings took the place of commercial, industrial, and residential buildings of the 19th century. During this period, Drexel came to look more like a traditional campus, with green spaces and pedestrianized streets while still managing diverse off-campus infrastructure and interfaces with the greater city: busy streets, neighbors who walk through campus, and transit demands such as parking and cycling.

CAMPUS LIFE: DIGNITY + IDENTITY

A special part of the campus experience in higher learning is the camaraderie and community that is created by learning, growing, and spending time together. While these experiences often happen within the classrooms and labs on campus, there are outdoor places within the public realm that foster traditions and underpin the rhythms of student life such as pre-game barbecues, rallies, alumni reunions, having a coffee, and club events. It is these events and memories that make attending a university more than an education but a memorable experience.

At Drexel, there is not one single “heart” of campus, but many special places where these events happen: the statue of Mario, Buckley Field, Main Building, Perelman Plaza, and the URBN Center are often recalled as special places on campus.

Yet, between these spaces, the quality of the public realm and the vibrancy of activity falls off quickly.

Because of this, the opportunity to gather, discuss, relax and play together as a Drexel community is diminished. Drexel is ripe with opportunity to create new settings for places that tap into its vibrant campus culture, with places of dignity, welcome and identity.



BUCKLEY GREEN AND 33RD STREET



MARIO THE MAGNIFICENT



URBN CENTER



CHESTNUT SQUARE

IMAGE OF THE CAMPUS

Kevin Lynch's seminal book, *The Image of the City*, identifies the criteria for analyzing a city for its memorability, identity and legibility based on cognitive mapping. Major and minor pathways, edges, key nodes, community districts, (which the West 8 team identified as villages), and major landmarks are all critical components to the urban campus.

Issues of tradition and memory are not addressed in meaningful ways in much of the existing campus. Where would you get your photo taken at graduation? What images would foster lifelong memories and connections to Drexel? What sensory or seasonal aspects would make the campus a beautiful and memorable experience? As the campus continues to grow, planning for these experiences is critical. They are fundamental components of campuses across the world

where students shape memories, create lasting relationships, and develop a strong bond with the campus and the institution.

Embedded throughout the Plan are opportunities for sensory experiences and visual images that would, over time, become part of Drexel's identity, to be carried throughout the world in memory and imagination. A boldly patterned walkway lined with a bright line of yellow-leaved ginkgo trees, a cascading series of lawns punctuated by stone steps, curved benches under a canopy of flowering trees: these would provide not only settings for campus life but also images to be remembered throughout a lifetime.

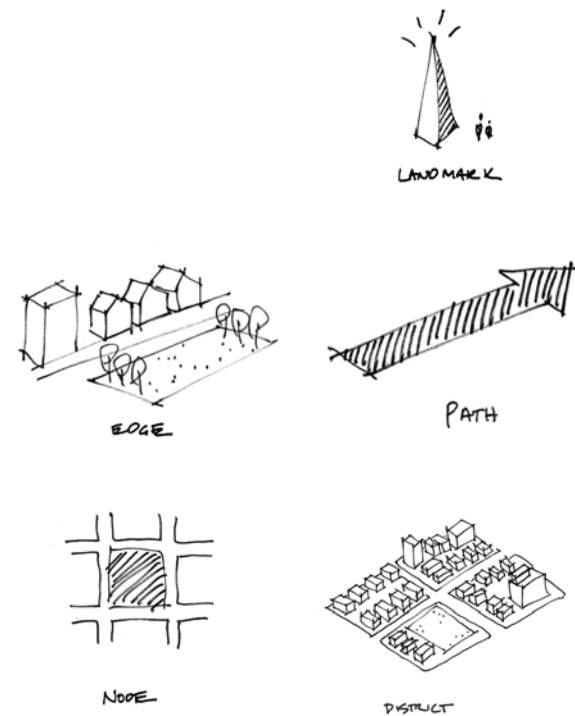

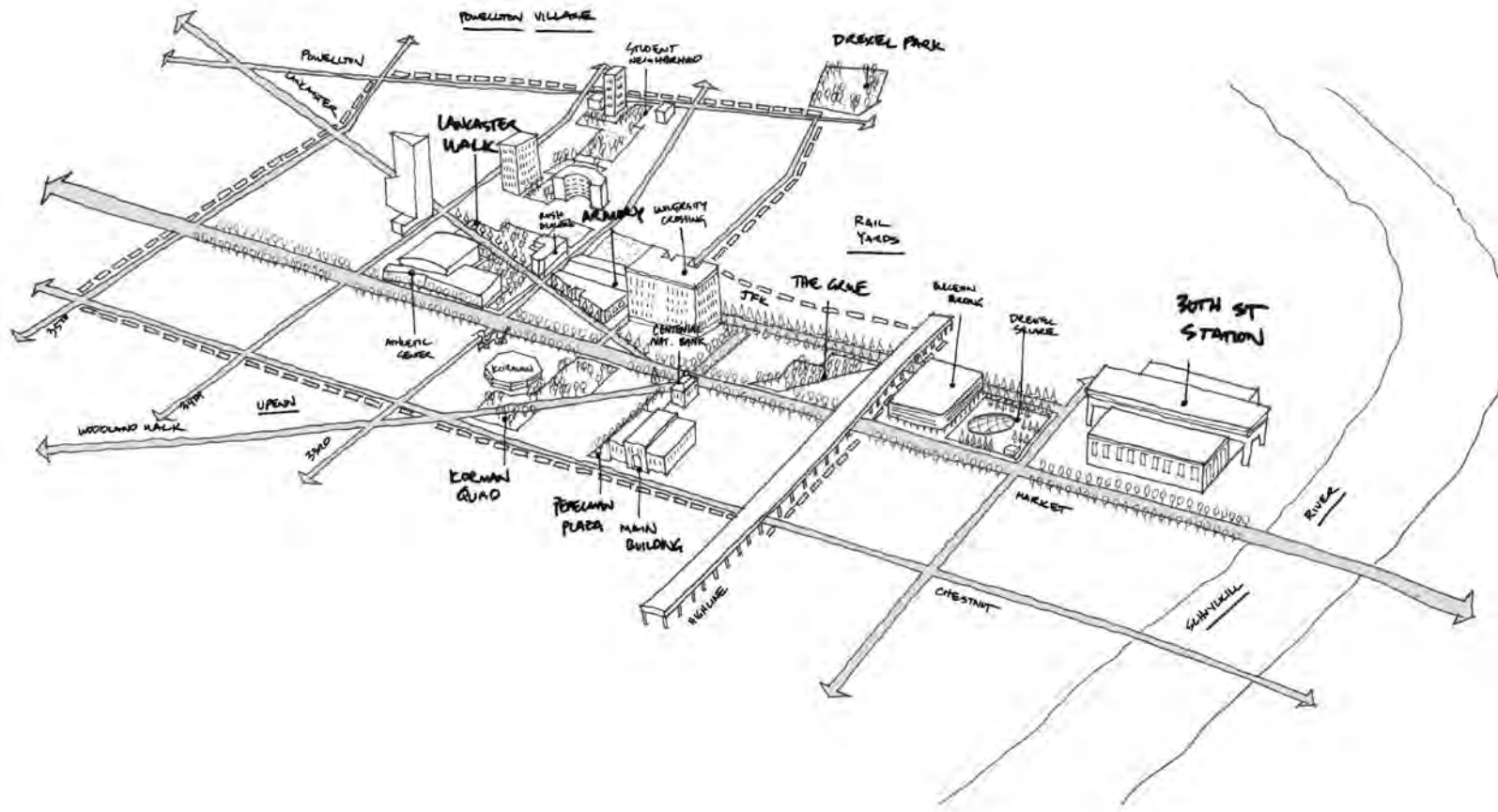

CONCEPTUAL ILLUSTRATION OF DREXEL UNIVERSITY PUBLIC REALM PLAN

URBAN DESIGN

The peak building period of Drexel's campus was in the 1960s and 70s. During this time, there was a movement in the urban design and architectural community to create campuses (both academic and office) as protected enclaves within cities. As a result, today at Drexel there are blocks of streets where Drexel's buildings are set back from the streets they face, with inactive ground floor uses and opaque facades. In some cases, the neighborhood's historic building fabric seemed to have been ignored, so transitions between tree-lined, small-scale residential areas contrast starkly with multistory, large footprint buildings. In addition, streets were closed to create pedestrian-only blocks, yet the backs of buildings face those pedestrian areas and as a result, lack a sense of welcome or activity.



THERE ARE A SERIES OF REMNANT SPACES ACROSS THE CAMPUS, OFTEN UNDEFINED AND VARIED IN MATERIALITY.



THE LANCASTER WALK VIEW SHED IS CURRENTLY MISALIGNED FROM THE HISTORIC CORRIDOR.



MARKET STREET IS ONE OF THE MAJOR GATEWAYS INTO DREXEL'S CAMPUS, AND A MAJOR PEDESTRIAN CROSSING.



THE STUDENT NEIGHBORHOOD AREA IS PRIMARILY A SERIES OF PAVED SURFACES IN WHAT SHOULD BE A SOFT AND PROGRAMMABLE SPACE.



SITE FURNISHINGS ARE VARIED ACROSS THE CAMPUS IN AGE, STYLE, COMFORT, AND LOCATION.

PUBLIC SPACE

In the last decade, Drexel has made strides in creating flexible, vibrant public spaces of high quality that support campus life. Yet many of Drexel's open spaces- its lawns, plazas and courtyards- seem to be more driven by function (such as loading docks, building entrances) or appear to be remnant space left over from a building's footprint. Furthermore, Drexel's 3.5 miles of streetscapes generally lack tree canopy, places to sit, and other supporting elements that make a street safe and inviting such as quality lighting and quality paving materials. Taken together, the public spaces at Drexel today lack a strong sense of pedestrian welcome or landscape quality. It is perhaps Drexel's biggest opportunity to create intentionally designed public spaces and streetscapes that support formal and informal public programming.



PERELMAN PLAZA



CHESTNUT SQUARE



RACE STREET



LANCASTER WALK AND 33RD STREET



DIAGRAM OF ESTABLISHED OPEN SPACES AND REMNANT SPACES ON DREXEL'S CAMPUS

PHYSICAL ANALYSIS: SYSTEMS AND MATERIALS ON CAMPUS

The systems of Drexel's public realm are interrelated or interconnected elements that are not site-specific but exist throughout the campus, such as lighting, street furnishings, stormwater management and traffic. Aesthetically, when designed with intention, systems lend the places and spaces they support a sense of unity and consistency. Currently, there is a wide range of lighting, street furnishings, and landscape materials across the campus, so that one does not get a sense of being in "the Drexel zone."



PARKING LOTS



FOOD TRUCKS



LIGHTING



STORMWATER



2

A VISION FOR A COHERENT PUBLIC REALM

Drexel is a well-established global research university and institution of higher learning, located in the heart of Philadelphia's University City, adjacent to the Schuylkill River and next to the hub of Amtrak's 30th Street Station.

To achieve the design vision requires substantial intervention over the long term, while a number of critical conditions require quick action. This Plan for the Public Realm is rooted in a framework that creates organizing gestures for gathering and meeting spaces, solves issues of circulation, and aims to improve the student experience. This Framework Plan takes the fundamental urban systems in the campus fabric and maximizes their significance through place-making and identity.

Conditions such as deferred maintenance, remnant spaces, outdated infrastructure, and inadequate facilities require an immediate plan of action and a clear direction forward. Additionally, Drexel's growing student body and academic community continues to put strain on the campus resources and student experience.

Drexel seeks to maintain and attract the best and brightest faculty and students. By updating and enhancing the public realm, student life and the experience on campus will be more visible. Drexel's robust culture will be showcased in the public realm, continuing the legacy of innovation and education.

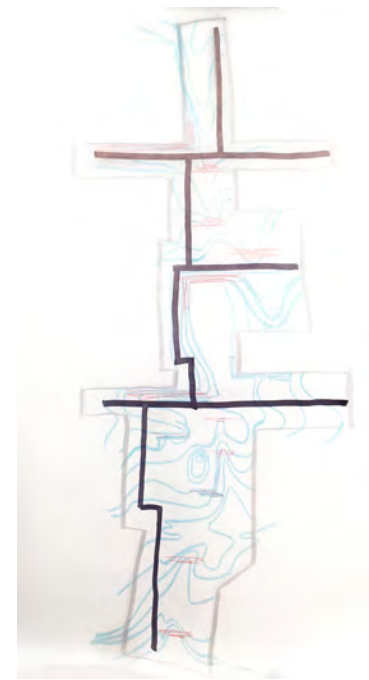

CONCEPTUAL SKETCH



UNIVERSITY OF
PENNSYLVANIA



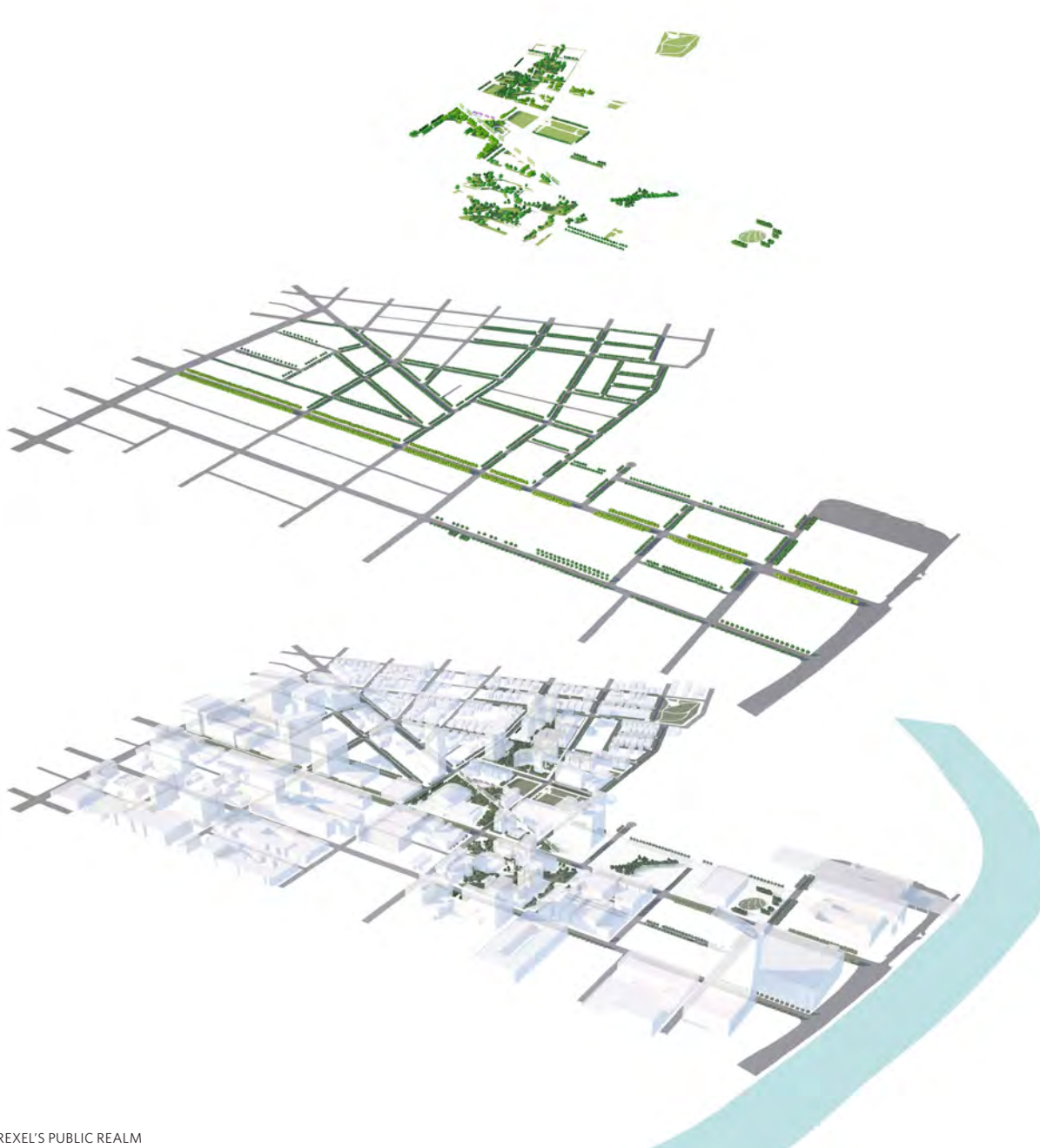

SYSTEMS THAT MAKE UP DREXEL'S PUBLIC REALM

3

PUBLIC REALM COMPONENTS

This Chapter elaborates the three components of Drexel's Public Realm: its streetscapes, its public spaces, and its campus-wide systems. Each section is further divided to provide additional details about specific places or concepts.

It is important to note that these Vision Plan illustrative drawings are not necessarily creating specific designs that are ready to be executed. There are further feasibility and design steps that would be needed to determine a specific design for the various areas identified. Rather, the illustrative drawings are meant to portray the potential for Drexel's public realm – a source of inspiration that allows one to envision a future much different than today's current conditions.

A

STREETSCAPES

Creating quality streets is more than conveying vehicles safely and quickly as high quality urban streets must allow for a safe and friendly environment for pedestrians, cyclists, and commuters. Drexel's campus is situated astride 3.5 miles of streets and sidewalks. While they are owned variously by the City of Philadelphia and the State of Pennsylvania, Drexel's streets and sidewalks are a signal component of the public realm which bisect, connect, and frame the edges of Drexel's campus. They are spaces in which people meet, wander, connect, and move. Currently, there is a wide variation in the width of right-of-ways, along with the character, use of materials, types of lighting, and the perceived levels of safety on the streets that run through campus. While the streets are a significant part of Drexel's urban identity, they are not only a part of the campus experience, but also how the local community and members of the greater Philadelphia region make their daily commute to work and home. Unlike many other campuses, which often have an internal network of circulation, much of Drexel's movement

requires the user to traverse the public right-of-way to get to their destination. For this reason, how the streets are designed is crucial not only to regional and neighborhood mobility and character, but also to the future identity of Drexel's campus. The goal for the Public Realm Plan is to present a vision of beautiful shaded neighborhood-scale streets which serve the University community, local neighborhoods, and the broader public. Active ground floors and shaded walkways, built upon stormwater best management practices aligned with the goals of the City of Philadelphia stormwater regulations, would provide Drexel the opportunity to be a leader and a model for public realm design for other universities and local communities. Additionally, parking both on-street and within parking lots was analyzed for opportunities to improve the public realm. This section presents preliminary schemes with visionary concepts to begin a discussion with the City of Philadelphia's Streets Department and adjacent communities.

IMPROVED INTERSECTION AT MARKET AND 34TH STREET





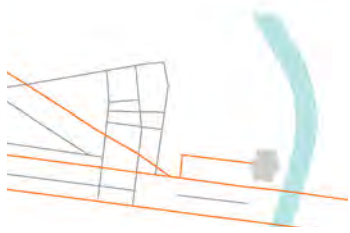

PRIMARY STREETS

Throughout the campus, certain streets are major arteries to other parts of Philadelphia, gateways into the campus, and anchors grounding the university within the urban street network. These primary streets have a historical legacy in Philadelphia. They were pivotal in the planning and development of the City, and continue to hold a significant impact over the campus circulation and identity today.



CHESTNUT STREET AND 33RD STREET

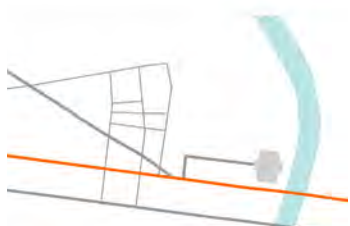

MARKET STREET: THE URBAN BOULEVARD

Market Street, Philadelphia's principal east-west axis, was established by William Penn and Thomas Holme in their landmark 1683 plan for Philadelphia. The first permanent bridge across the Schuylkill River was opened in 1805 connecting what is now Center City with townships west of Philadelphia. Market Street intersects with Broad Street (Philadelphia's principal north-south axis) at Philadelphia's City Hall and is the prime gateway into Drexel's campus on the western side of the Schuylkill River. At the river crossing on the eastern end of campus, Market Street is flanked with significant early 20th-century architectural landmarks, Amtrak's 30th Street Station and the former United States Postal Service building. The grandeur of this arrival experience quickly dissipates upon entering campus.

Market Street separates the academic core of campus from academic, recreational and housing areas to the north, making many students cross it multiple times throughout the day.

Of all the streets that run through the University City campus, Market Street has the greatest opportunity for a transformative effect on campus life and Drexel identity – continuing the transformation begun in the mid-1950s, when the subway was extended west from Center City, replacing the easternmost portion of the Market Street elevated train line.

The proposed cross-section of Market Street in this plan would make the street feel like a grand boulevard: a double row of street trees would provide a shaded space for pedestrians and cyclists, and frame a safe cycling corridor. Best practices for stormwater management would be integrated

into the design. Given Market Street's critical importance in the hierarchy of Philadelphia's street grid, this would showcase Drexel's and the City's commitments to enhancing cyclist and pedestrian safety, decreasing the deleterious impact of Philadelphia's impervious surfaces and enhancing the experience of public life on Philadelphia's central corridor.

This vision for Market Street has been coordinated with parallel plans for Schuylkill Yards, with the intention of creating a seamless transition. This vision is a starting point for further collaboration with the many groups of stakeholders in the future of this important urban street.

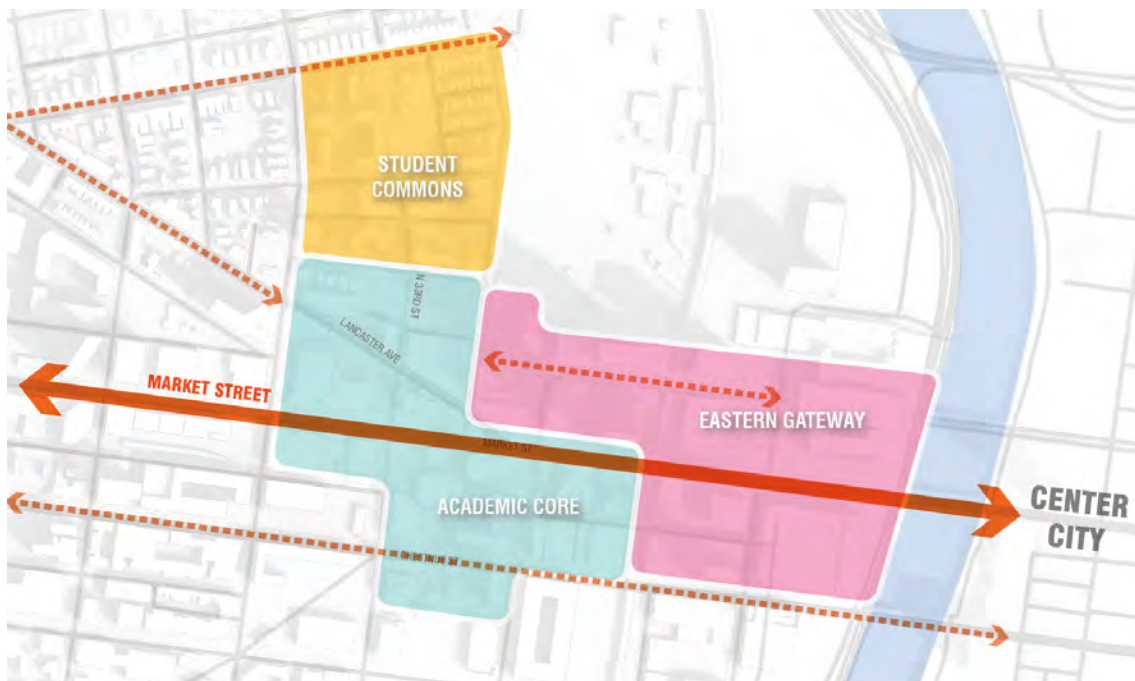

MARKET STREET IS A CRUCIAL CONNECTION FOR DREXEL



HISTORIC PHOTO 1908



CONDITIONS TODAY



SUBWAY: MARKET - FRANKFORD LINE

SECTION

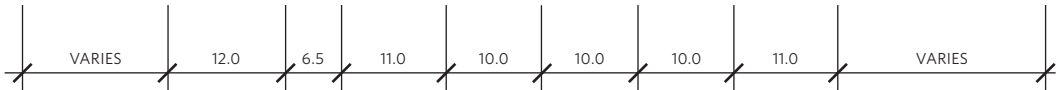
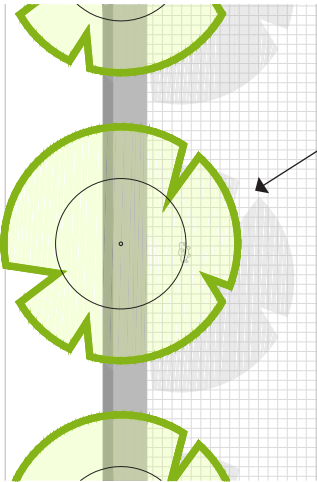
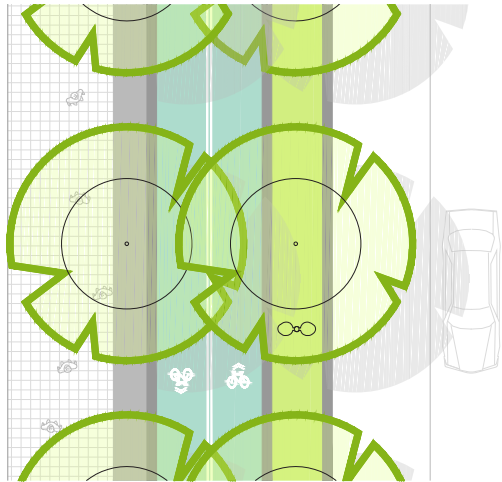

PLAN





VISION FOR MARKET STREET



CHESTNUT STREET

Chestnut Street is one-way eastbound from its starting point at 63rd Street, through Drexel’s campus and across the Schuylkill River, to Center City, where it becomes a major commercial corridor. Recent improvements to the housing, shopping and restaurant offerings on Chestnut Street within Drexel’s campus draw visitors from beyond Drexel’s boundaries.

The City is currently considering improvements to Chestnut Street, including a protected bicycle lane on the north side of the street. Additional improvements to this critical commercial corridor could vastly enhance the quality of mobility, pedestrian experience, and stormwater retention capabilities within this part of the campus. In particular, a formalized mid block crossing across Chestnut between 32nd and 33rd Streets – including raised crosswalks and high-visibility street markings -- would reflect pedestrian desire lines, enhance safety, and serve as a traffic calming measure.



TOP: EXISTING CONDITIONS OF MID BLOCK CROSSING
 BOTTOM: CURRENT CONDITIONS



SECTION

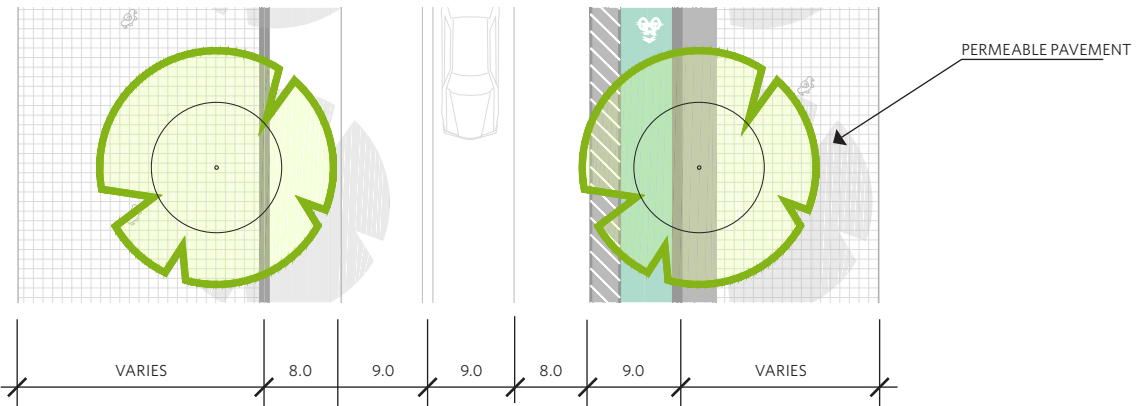

PLAN

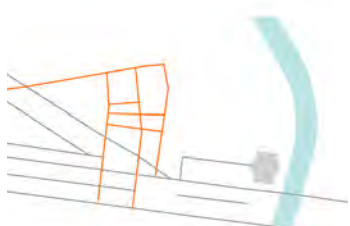

SECONDARY STREETS

Secondary streets are the intimate, residential streets adjoining Drexel's West Philadelphia campus. These secondary streets define a relationship between the areas they transect from the Drexel Community to the residents of Powelton Village, Mantua, and West Powelton. The variegated edges of these streets create a permeable border of the residential campus and allow for the creation of intimate gathering spaces between residence halls within Drexel's Northside Campus. Many of these streets could be improved by generous shaded walkways and protected bikeways for the Drexel community and local residents; specific recommendations should have the input and support of both the City and local residents.



SECTION

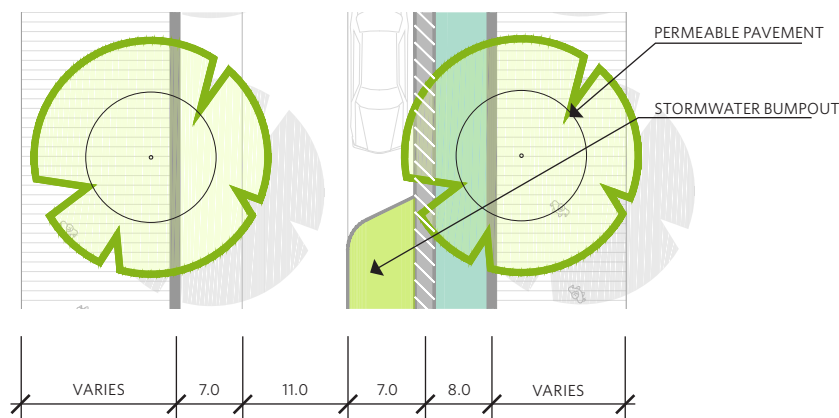

PLAN

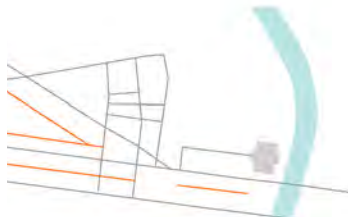

TERTIARY STREETS

Tertiary Streets are the final thread in the circulation fabric of Drexel's campus. These streets are not heavy for vehicular circulation but often used for pedestrian corridors, service and loading, and building entrances throughout the campus.



SECTION

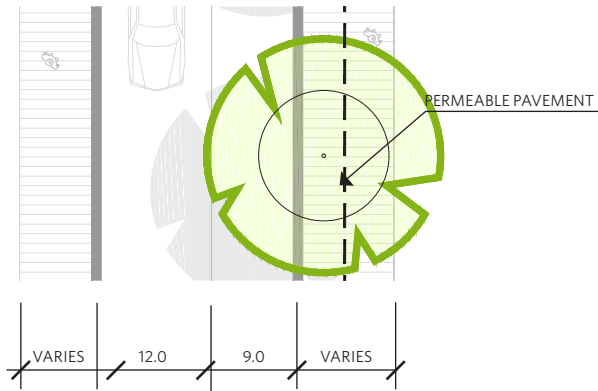

PLAN

PARKING

Improvements to the quality of streetscapes – including the addition of bicycle lanes – should be balanced with parking demands. Over time, parking could be displaced by development of surface lots, necessitating broader parking studies and plans. These plans should prioritize bicycle and pedestrian safety and amenity alongside automobile transportation and parking. In the future there should be an overall parking strategy for the campus that address future trends and developments.



TEMPORARY AND PERMANENT PROGRAMMING COULD ACTIVATE PARKING LOTS



B

PUBLIC SPACES

Drexel's proximity to Center City makes the campus open space network a visible and prominent part of Philadelphia's urban fabric. Therefore, these spaces must serve multiple purposes for students, visitors and residents. A well-designed campus provides students with spaces for active programs as well as passive respite. The location of Drexel's campus within the heart of urban Philadelphia calls for a planning approach which promotes the support and further development of multiple-use spaces on and around the campus.

Perelman Plaza is major gathering space which can be programmed for large-scale campus events, formal ceremonies, and weekly gathering spaces for both students and the neighborhood; Lancaster Walk and Korman Quadrangle have the potential to host other kinds of large events. Additionally there should be a series of spaces for smaller, more

informal student-organized events – pick-up sports, barbecues, study groups, or casual meals with friends. Both types of public spaces – formal and informal – are crucial for a healthy campus and an active student body. The following chapter discusses these types of spaces and describes a bit more about their character and development for the future of the campus framework.



DIAGRAM OF PROGRAMMABLE AND FLEXIBLE OPEN SPACES ON CAMPUS

LANCASTER WALK

Historically, Lancaster Walk was the terminus of Lancaster Avenue running through Drexel's campus connecting Philadelphia to Lancaster. Today, the walk runs through the campus connecting the residential campus to Market Street and the academic core. Currently, Lancaster Walk is a sidewalk in the campus fabric, divided into three parts while the historic view corridor - with a vista of Frank Furness' Centennial Bank - is blocked by trees and food trucks. A transformation of this space into a new central organizing feature of the campus would create an important gathering place for the community.

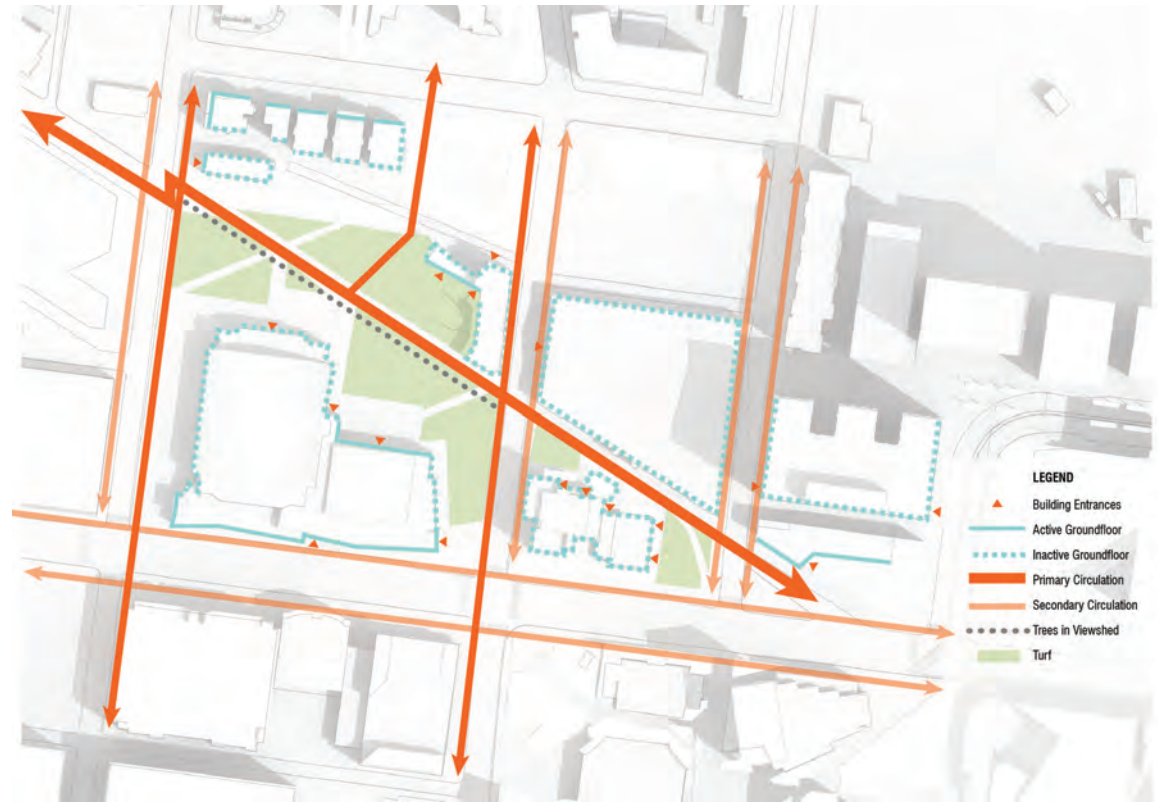

DIAGRAM OF EXISTING SITE CONDITIONS



DESIGN VISION FOR LANCASTER WALK

MAJOR ELEMENTS

The multi-block, pedestrianized area that connects with Lancaster Avenue has significant potential to be a place beauty for gathering and walking and a demonstration of Drexel's sustainable development values. Additionally, a redesign would restore the Lancaster Avenue viewshed. New lighting, water features, rain gardens, tree planting with seasonal splendor and seating will make this space a year-round place for the Drexel community.



PLANTING A WALK FOR THE SEASONS

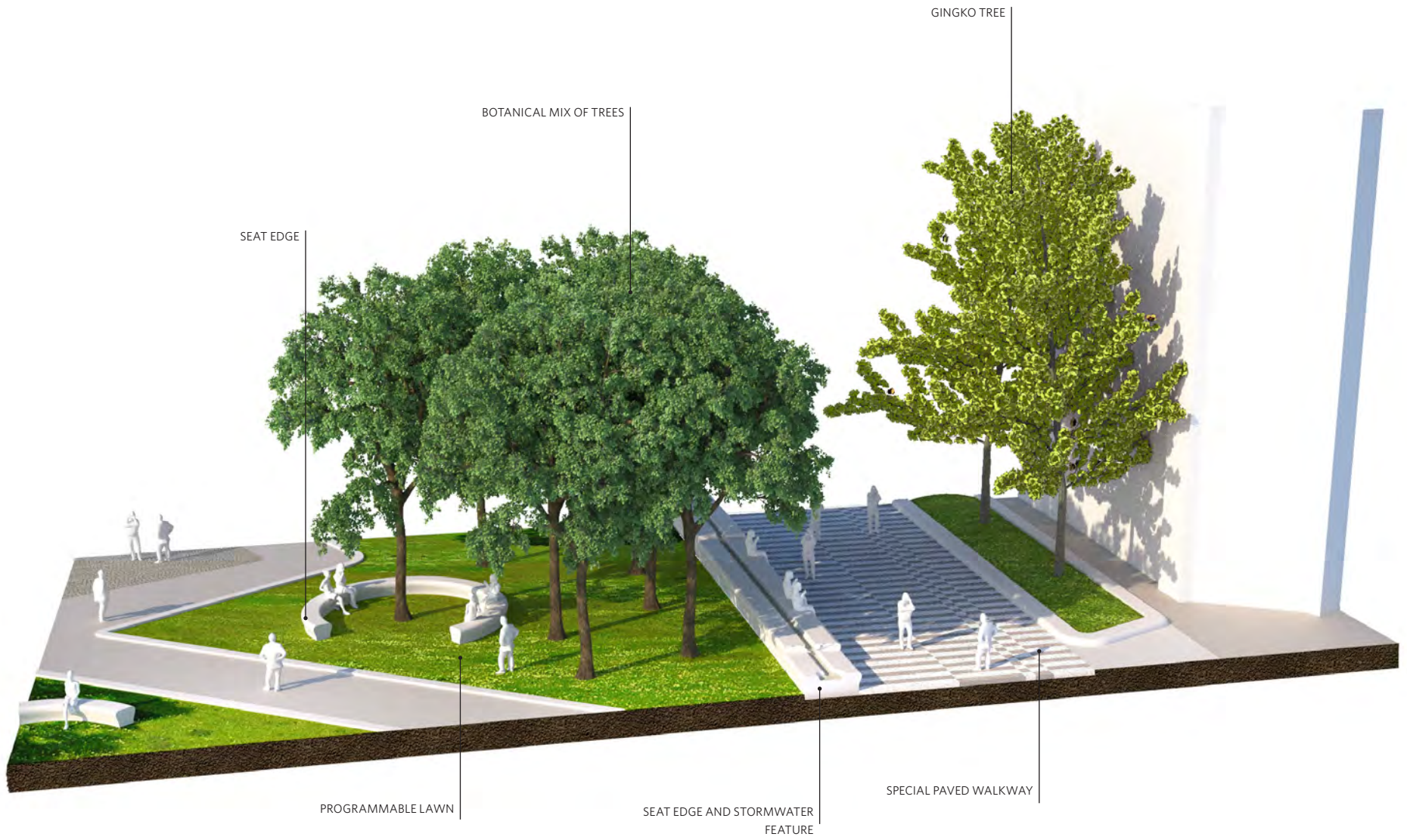

THE ELEMENTS ON LANCASTER WALK

MATERIALS

The material palette of Lancaster Walk should be similar to the other materials used in special spaces on campus; however, the design should have features which are unique to the walk. The paving for the walk is an opportunity to create a graphic identity through color and pattern. This would provide a strong visual connection through the three segments of the walk, visually connecting Market Street to the activity on Lancaster Avenue beyond.

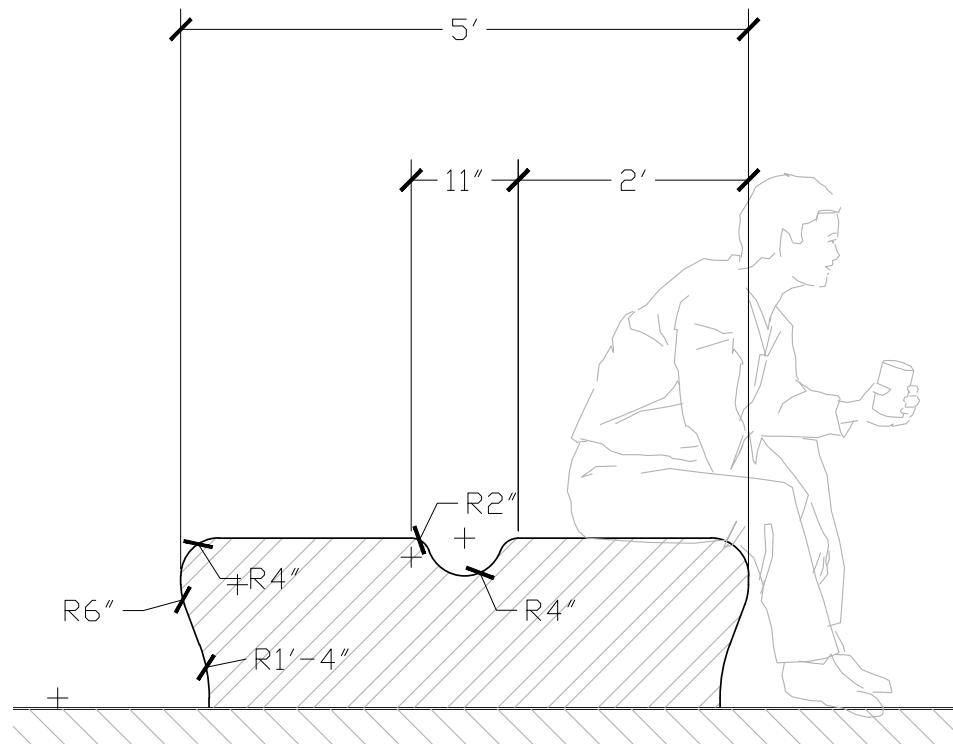

PROPORTIONS OF THE STORMWATER FEATURE SEAT



LEFT: STUDIES IN GRAPHIC PAVING; RIGHT PAVING PRECEDENTS

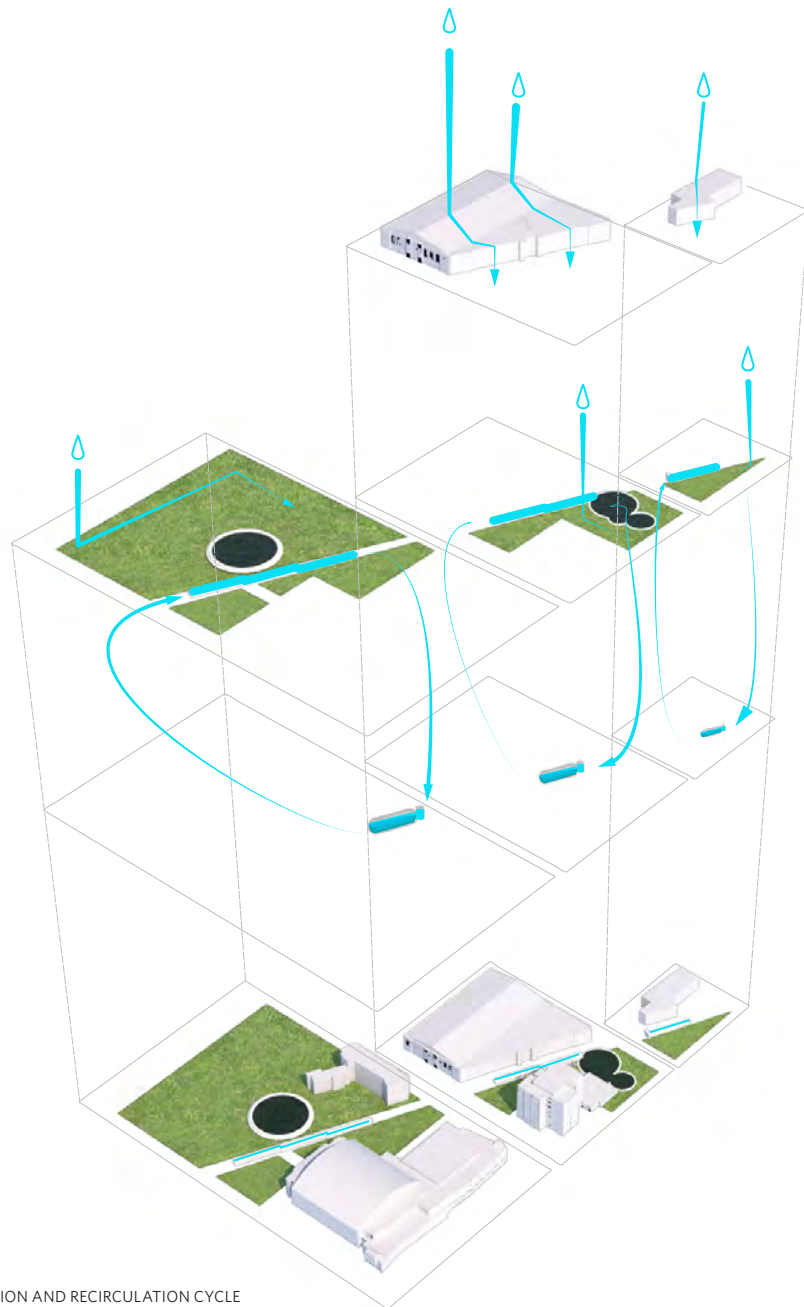

STORMWATER COLLECTED FROM THE ROOFS OF THE ADJACENT BUILDINGS DURING RAIN EVENT

DRAINS THROUGH THE PERMEABLE SURFACES

WATER IS COLLECTED IN THE SUBSURFACE DETENTION BASINS

THEN RECIRCULATED THROUGH THE WATER FEATURE

STORMWATER COLLECTION AND RECIRCULATION CYCLE



ABOVE: REFLECTING POOL; BELOW: RAIN GARDEN AT MIT STRATA CENTER;
RIGHT: STORMWATER RUNNEL



STORMWATER

Lancaster Walk's unique positioning running downslope from a high point of the campus landscape to the lowest point, creates the perfect dynamic for a central, celebratory water feature on campus. Being able to see the water flow down this slope in a series of water-focused design elements would draw the public and the university community to share this space along this historic street. As rain falls atop adjacent buildings and nearby lawns and plazas, it would drain into subsurface detention basins beneath Lancaster Walk. These basins would pump filtered water into the water runnels within the custom seating along the south side of Lancaster Walk, allowing people to sit and touch the water as they gather in these areas. The subsurface basins would also regulate the water within the two open pools along Lancaster Walk. While one would act as a clean reflection pool containing filtered water, the other would filter the water on site via select riverine plantings.





FEATURING NEW PLAZA AND LANDSCAPE ON LANCASTER WALK

STUDENT NEIGHBORHOOD

Roughly 20 percent of the student population currently lives on campus. Many of these students, including most freshmen, live in this northern area above Market Street. Seven major residence halls make up this student neighborhood, each varying in density, context, and age. Today, the conditions of this area are not supportive of active student life. The Plan’s vision for this student neighborhood would unify disparate and fragmented landscapes into a green, centralized place of relaxation, shade and gathering for students. Walkways would provide clear and well-lit access to building entries and connect to the surrounding neighborhood. Undulating turf lawns would be punctuated with seat edges for informal places to hang out or play and for small-sized programs like lectures or performances.

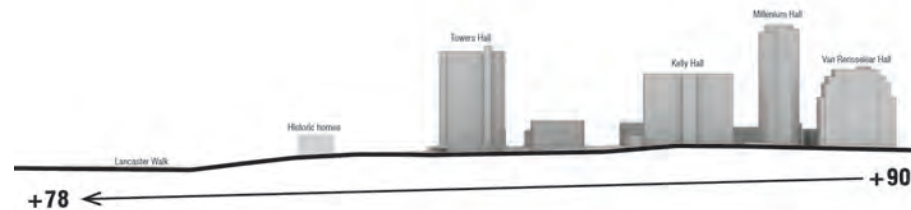
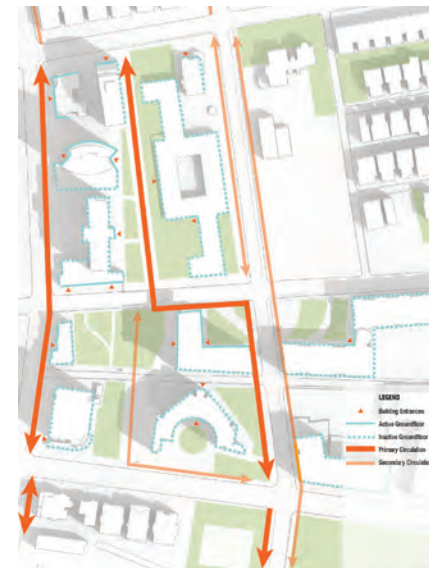

ABOVE: DIAGRAM OF EXISTING CONDITIONS;
BELOW: CHANGE IN GRADE



DESIGN VISION FOR THE STUDENT NEIGHBORHOOD

MAJOR ELEMENTS

One of the major components missing from the student neighborhood is vegetation. The percentage of hardscape is dominant with the closing of Race Street, Spangler Walk, and the parking lot between Towers and Calhoun; these are all significant spaces in the student neighborhood which could be converted into flexible open space. Replacing these surfaces with lawn would open up new opportunities for gathering, events, sports, and festivals. Additionally, a series of varying length seat edges throughout the site could be used as informal or event seating, and would create small plateaus for performances or events. They would add a new opportunities for programming the space.



INSPIRATION IMAGERY FOR THE STUDENT NEIGHBORHOOD

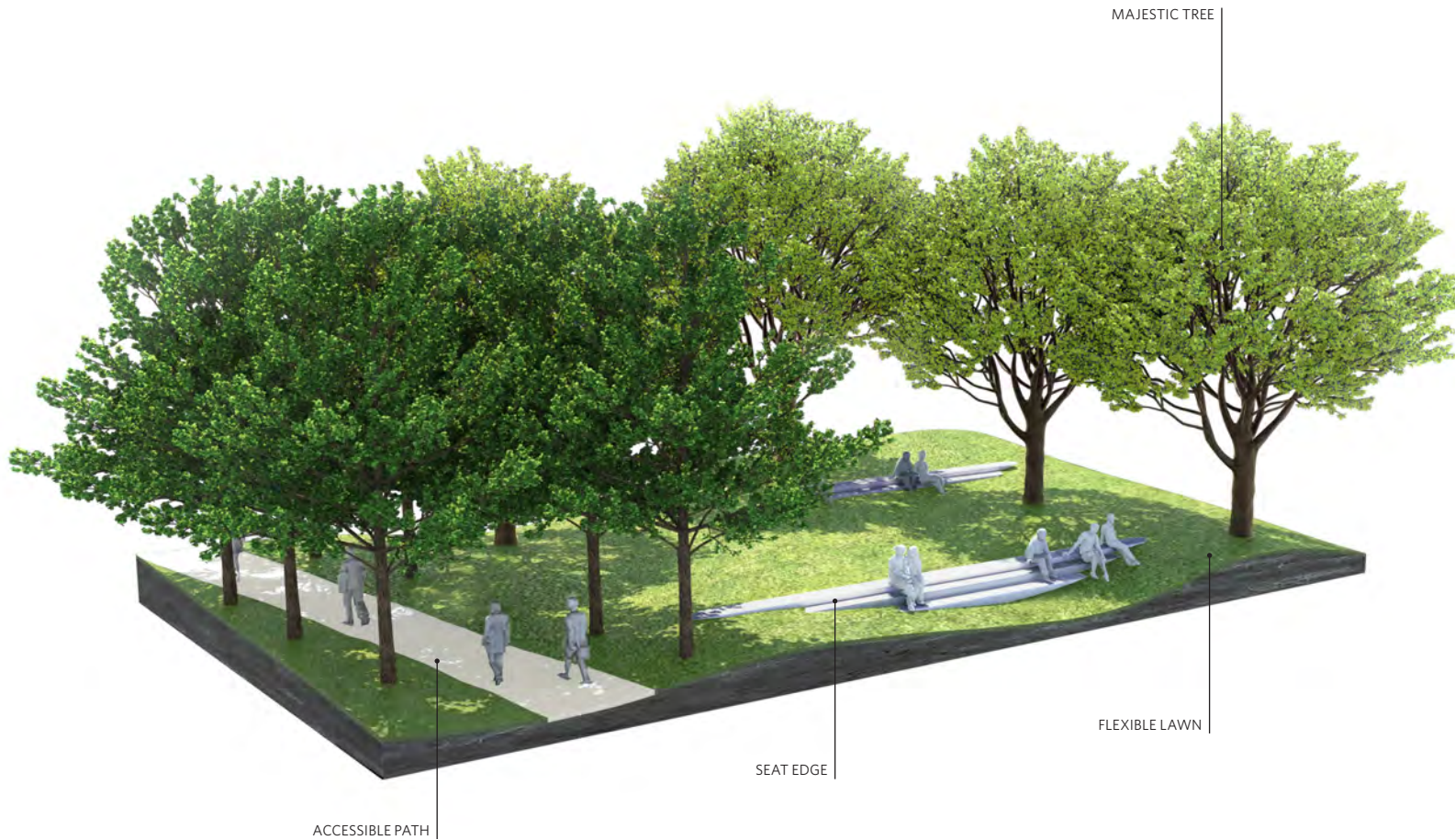

THE ELEMENTS OF THE STUDENT NEIGHBORHOOD

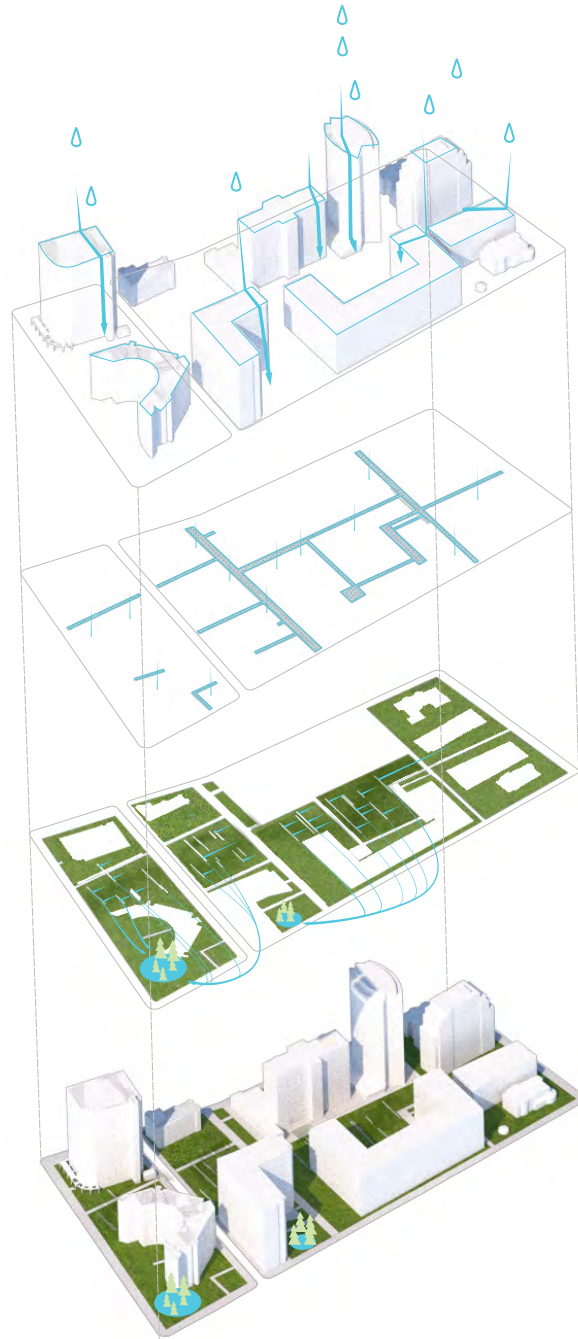

STORMWATER COLLECTED FROM THE ROOFS OF THE ADJACENT BUILDINGS DURING RAIN EVENT

DRAINS THROUGH THE PERMEABLE PAVEMENT AND PLANTED SURFACES

WATER IS COLLECTED IN THE SUBSURFACE DETENTION BASINS AND SHED TO RAIN GARDENS

STORMWATER COLLECTION AND RECIRCULATION CYCLE



ABOVE: DIAGRAMS SHOWCASING THE STORMWATER FEATURE SYSTEMS
 RIGHT: RAIN GARDEN PRECEDENT

STORMWATER

The proposed student neighborhood vision would take advantage of the open areas within the blocks of residence halls along 33rd and 34th streets. Within this area of generous lawns and gently sloping hills and valleys, seating would play a double role as both hidden stormwater drainage features and student gathering areas. As water ran down the southward slopes of the lawns, it would drain into aggregate placed out of sight behind northern seating edges. Water would then flow into a perforated pipe which would drain into the two stormwater retention basins at the low points of the residence hall blocks. These low points would become richly planted areas designed to absorb water above ground while also detaining excess water in cisterns below ground. These areas would provide great locations for urban habitat zones, art locations as well as stormwater management study areas for students to monitor.





NEW CAMPUS QUAD FOR THE STUDENT NEIGHBORHOOD

SCHUYLKILL YARDS

The Schuylkill Yards development is a long term development project between the Schuylkill River and Drexel's campus. A partnership with Brandywine Realty Trust, the 14-acre development will be a mix of residential, retail, office, academic, and open space. The transformation from parking lots to a new district will take a number of years and will ultimately connect Drexel's campus to Schuylkill Yards through the extension of Woodland Walk, a promenade on JFK Boulevard, and a new prominent open space in front of the Bulletin building - Drexel Square.



IMAGES FOR SCHUYLKILL YARDS

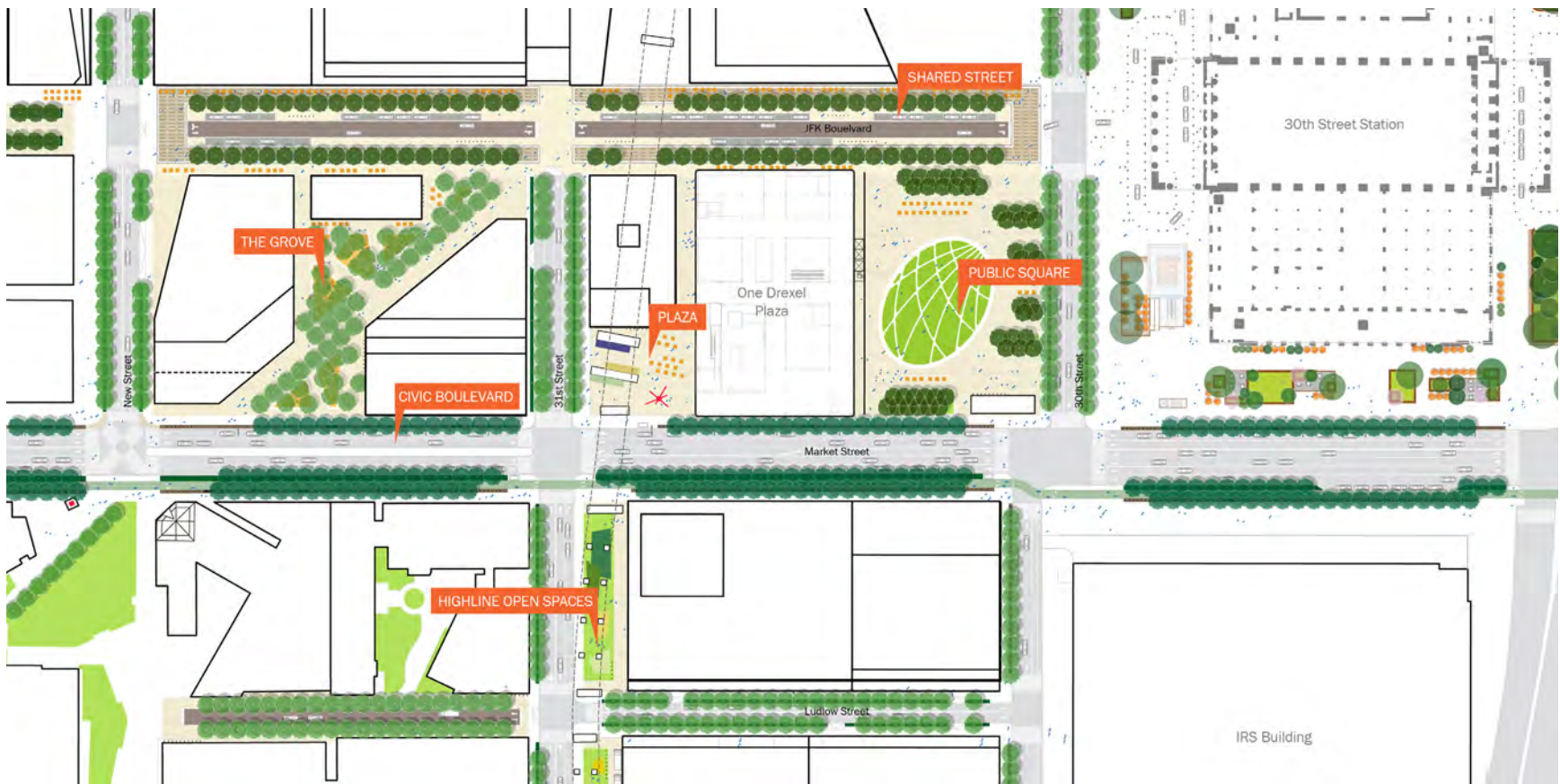

SITE PLAN OF SCHUYLKILL YARDS





DREXEL PARK

Drexel Park is uniquely situated at the northern edge of the campus, next to the student neighborhood and on the edge of Powelton Village. It offers sweeping views of downtown Philadelphia and a large open lawn for students and neighbors to enjoy. It is the perfect place of overlap for the two groups, and is one of the contributions Drexel gives back to the community.



KEY CHARACTERISTICS FOR THE AREA



DREXEL PARK AND POWELTON VILLAGE

KORMAN QUAD

A central space in the campus framework, Korman Quad is currently undergoing a renovation to make the Quad more green and park like. The location and use of this space makes it a critical component of the campus future framework.



IMAGES BY ANDROPOGON

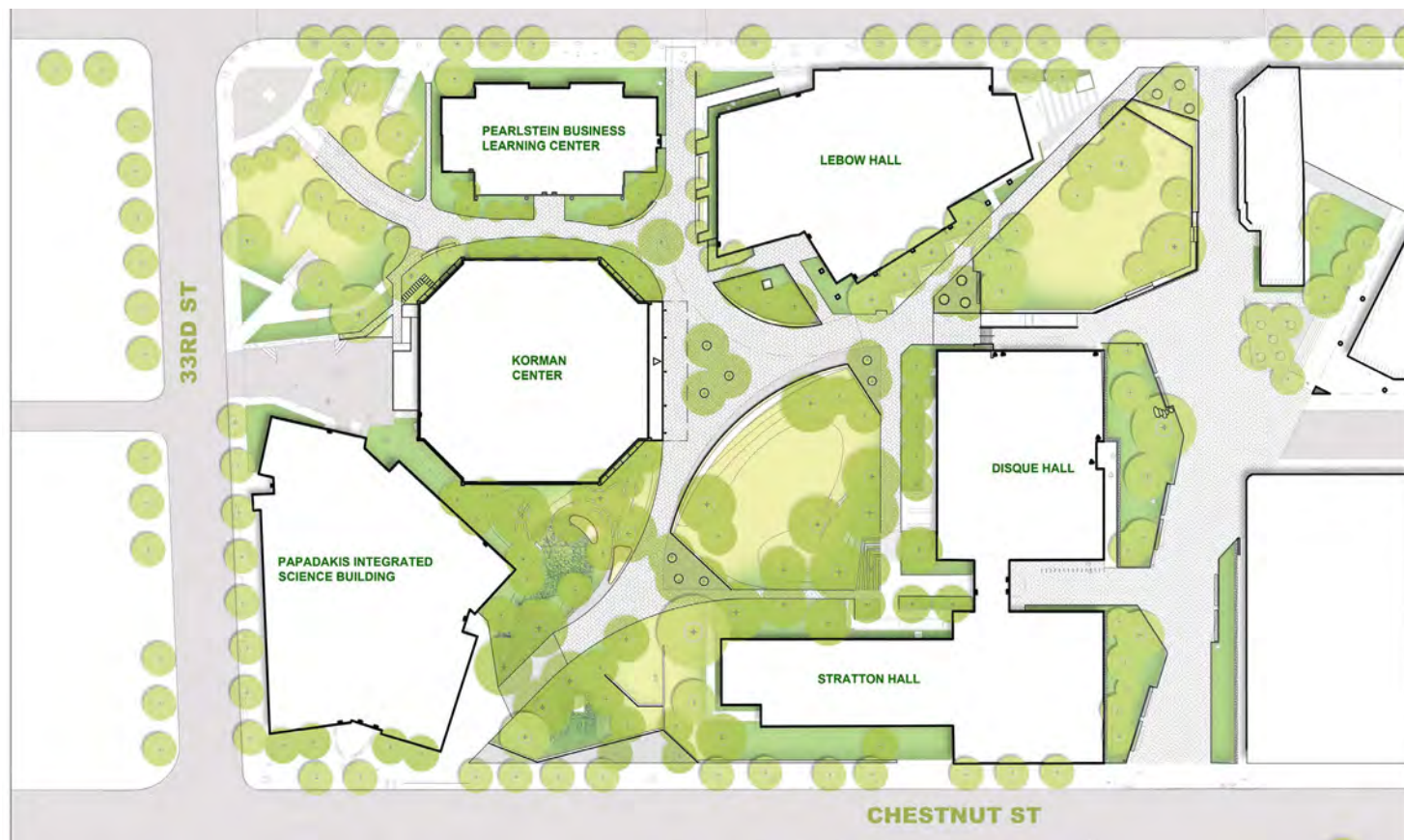

SITE PLAN BY ANDROPOGON

UNIVERSITY HIGH SCHOOL SITE

Adjacent to Drexel’s campus, the site of the former University City High School - purchased in a joint venture of the University and Wexford Science + Technology - will be a new development of office, laboratory, academic, and residential uses. The project will reintroduce the street grid that was removed in the 1970s and include a series of pedestrian corridors cutting through the development and connecting to the western side of Drexel’s campus.



IMAGES BY OLIN



SITE PLAN BY OLIN AND AYERS SAINT GROSS

C

SYSTEMS

Stormwater, lighting, street furnishings, and signage are all campus-wide systems which complete the overall campus framework. Each of these entities is a critical component for the campus and serves to create a sense of identity and clarity for the public realm while performing critical functions. These systems should work together, overlapping with each other in a clear and sustainable fashion. Circulation should be clear and direct as well as comfortable and safe. Streetscapes should include adequate lighting, signage, stormwater retention capabilities, and street furnishings, as well as have a strong sense of identity. The goal is for each system to work in tandem with the other systems and bring a level of clarity, composition and beauty to the campus - particularly in areas that are currently under-defined and underperforming. This chapter will explain the goals for each system, how they work individually and together, and how they can help shape the future framework of Drexel's campus in conjunction with policy goals of the City of Philadelphia.





Drexel

CITY STORMWATER PLAN

By addressing stormwater runoff in its open areas and streetscapes, Drexel has an important opportunity to play a key role in aiding the City of Philadelphia's Green City Clean Waters Plan to decrease pollutants entering the Schuylkill River by 85% over the next twenty years. Uniquely positioned as a gateway between West Philadelphia and Center City, Drexel's streetscapes have the potential to influence the stormwater agenda within its surrounding context and link into the fabric of the current projects Philadelphia has already implemented and proposed. Building on the Philadelphia Water Department's guidelines to implement stormwater trees, tree trenches, bump outs, planters, pervious pavers, and runnels, the Plan's recommendations are to continue this language throughout the campus fabric.

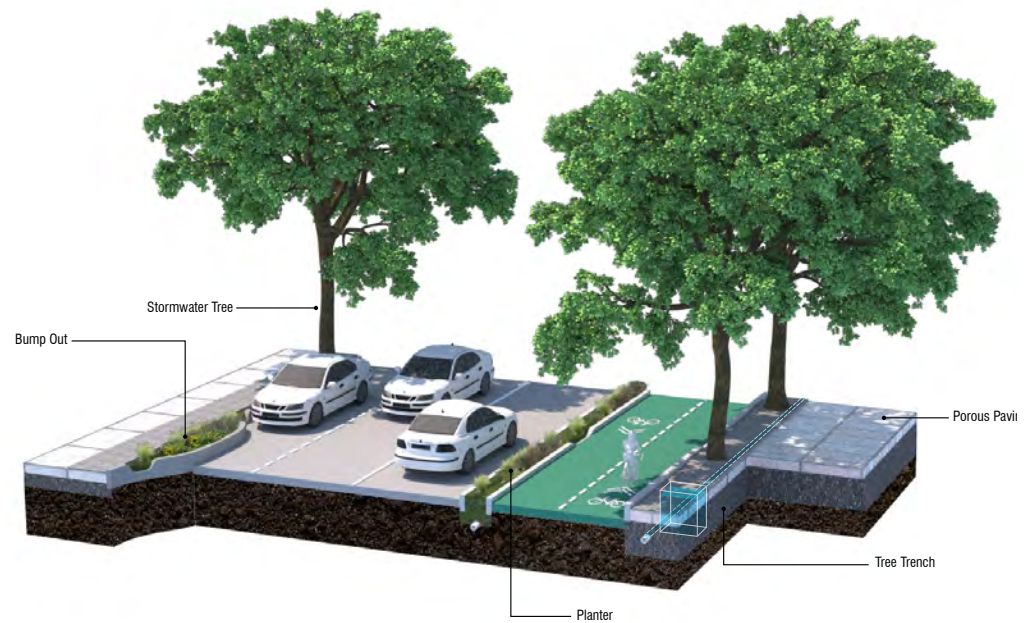

DIAGRAM SHOWCASING A COMPLETE GREEN STREETS

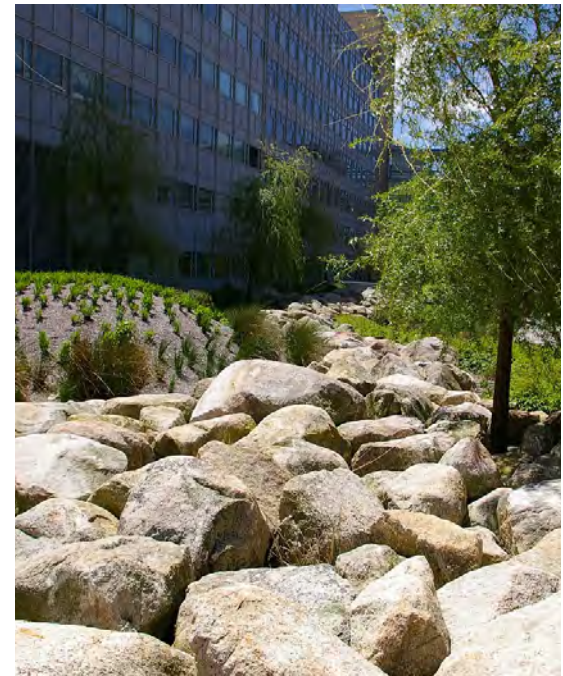

DIAGRAM OF EXISTING CITY STORMWATER IMPLEMENTATION PROJECTS

CAMPUS STORMWATER OPPORTUNITIES

Stormwater management should be a prominent and visual system in the campus landscape. The Plan proposes three significant drainage areas totaling six acres of land which would be able to divert and filter 36,000 cubic feet of stormwater during a typical stormwater event. The realization of each of these areas would result in environmental, social and economic benefits. Increasing habitat, improving groundwater recharge, reducing heat island effects and reducing combined sewer overflows would be important but largely unseen results. The social benefits would include an improved public realm and social atmosphere for the Drexel community and neighbors, as well as economic gains from reducing stormwater service charges from the city.

The three strategic areas of stormwater detention include the Student Neighborhood, Recreational Fields, and Lancaster Walk. In these three distinct social zones of the Drexel campus, the community would be able to enjoy the pleasurable garden-like spaces where water would be diverted into stormwater basins outside of main gathering areas. On Lancaster Walk, the water collection would be celebrated through the runnel feature on the seating along the Walk's southern edge. These water features would add to the identity of the campus, helping establish a new landscape vocabulary for Drexel.



STORMWATER PRECEDENT



DIAGRAM OF PRIORITY CAMPUS STORMWATER SITES

LIGHTING

Current campus lighting is an amalgamation of planned and incident-based lighting solutions. The driving factor behind many of the incident-based lighting solutions has been a direct response to public safety concerns. Each circumstance that required “more lighting” has been primarily resolved by adding more lighting equipment which establishes higher light levels but also introduces disabling glare. The extensive variety of lighting equipment used on Drexel’s campus requires an extremely large inventory of replacement lamps and fixtures. When maintenance is required, it may take more than one visit to identify the lamp and return with a maintenance crew and the right replacement. Additionally, high pressure sodium sources are not effective at rendering colors, which is crucial when discerning details of people and objects in the surrounding environment. This process of incrementally addressing campus lighting and the overall condition has created a lighting environment in need of comprehensive consideration. Particular

attention must be paid to average illuminance uniformity, glare and light source color properties. While it is important to maximize the potential for the aforementioned mechanisms/deterrents they should not be followed to the detriment of the inherent, cultural or historic character of the neighborhood or street. Overly uniform and overly lit spaces can also result in negative and anti-social behaviors.

The key is to strike the appropriate balance between maintaining the character of the place, and improved feelings of safety and informal surveillance.



PRECEDENTS: GOVERNORS ISLAND



PRIORITY LIGHTING AREAS ON CAMPUS



LIGHTING AT THE STUDENT NEIGHBORHOOD

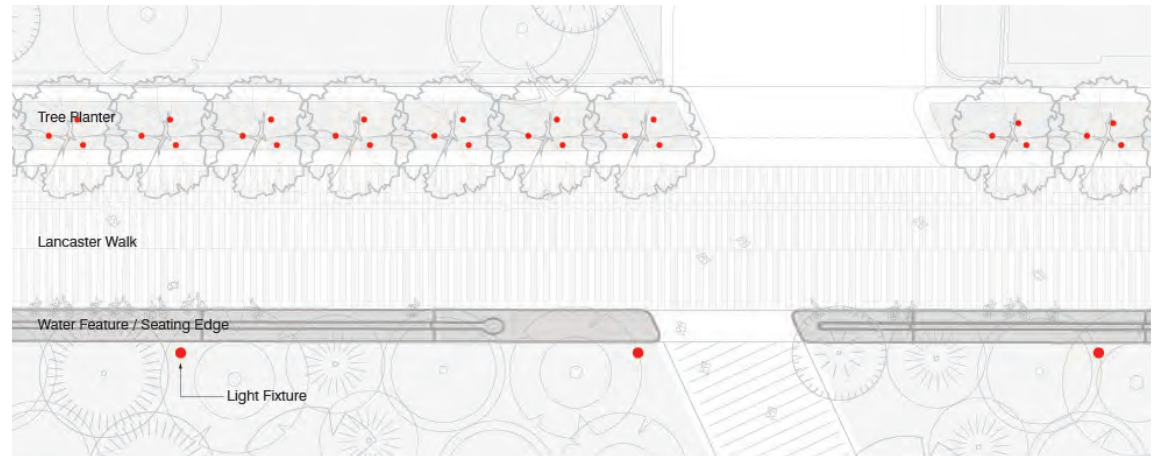

PLAN OF PATH LIGHTING AT LANCASTER WALK

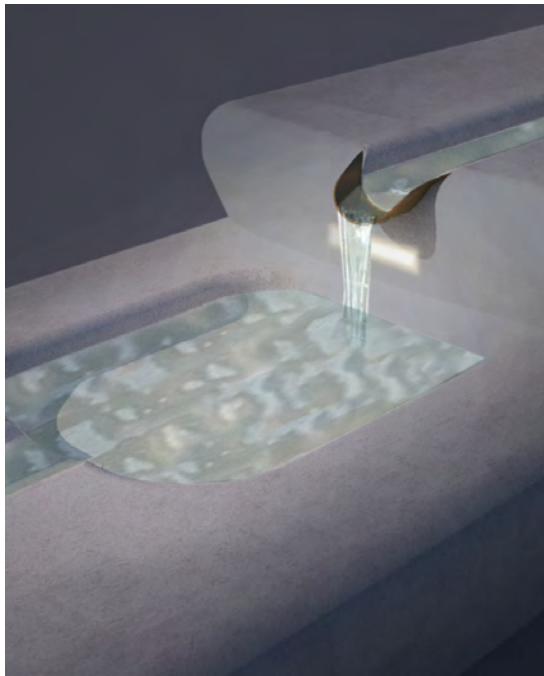

FEATURE LIGHTING AT LANCASTER WALK



SECTION OF PATH LIGHTING AT LANCASTER WALK

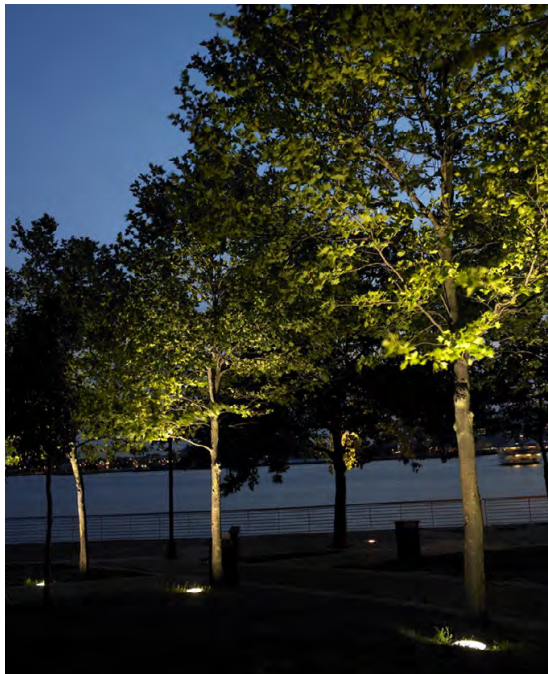

UP-LIGHTING TREES ON CAMPUS, PRECEDENT

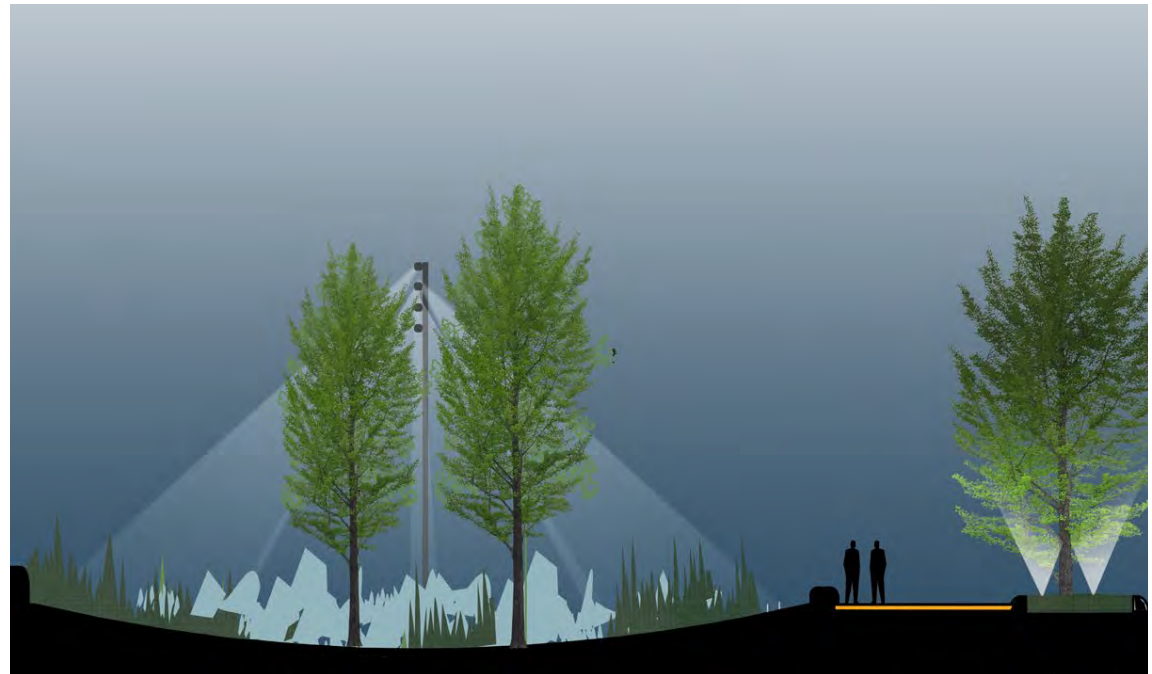

UP-LIGHTING WETLAND ON PROPOSED LANCASTER WALK



GREEN SCREEN ALONG 32ND STREET

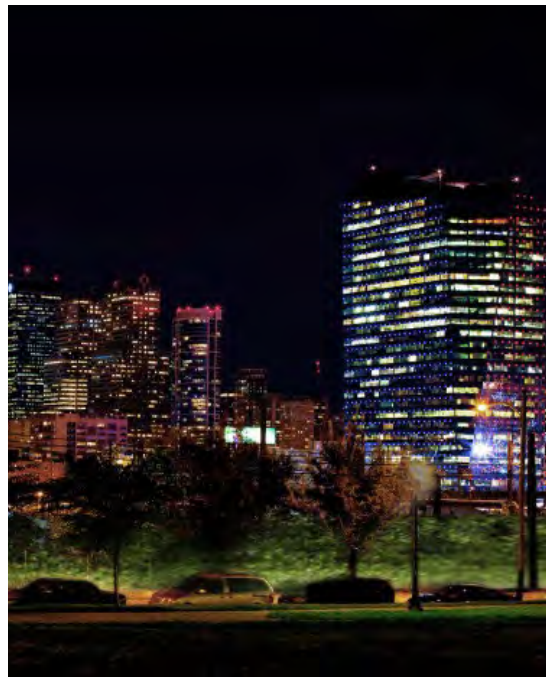

UP-LIT SCREEN ON 32ND STREET

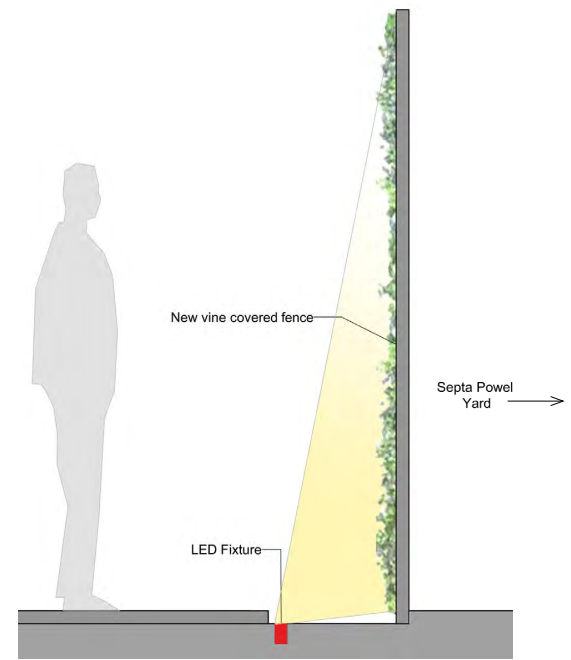

UP-LIT GREEN SCREEN

FURNISHINGS

Site furnishings are crucial elements of the public realm. Benches, tables and chairs, trash receptacles, bike racks, and light fixtures provide amenity to campus life and contribute to the University's visual identity.

Currently on Drexel's campus there are many different types of furnishings - including both positive examples and outdated or inappropriate pieces remaining from older projects. The mixture of materials, types, and styles does not create a coherent language or identity. The design team recommends editing, culling, and augmenting existing site furnishings, and sets out guidelines for doing so in a companion document to this Plan. The Plan identifies a hierarchy of spaces: special areas appropriate for custom-designed furnishings, and areas in which products purchased from a distributor or manufacturer would be most appropriate.



OFF THE SHELF: FERMOB, LUXEMBOURG SERIES



OFF THE SHELF: HAUSER, ADIRONDACK CURVE BACK COMPACT CHAIR



OFF THE SHELF: LANDSCAPE FORMS, COLLECT SERIES

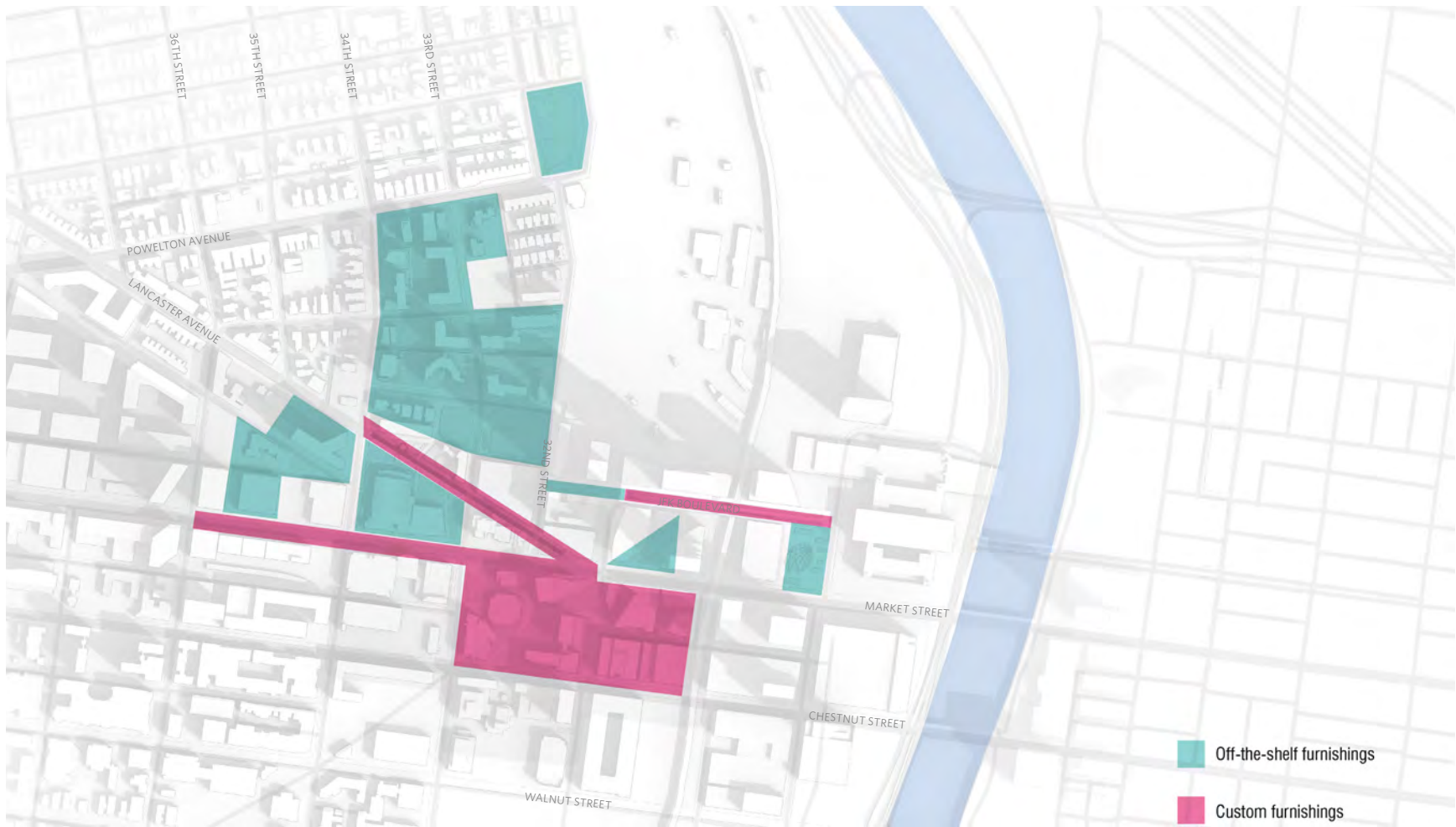

DIAGRAM OF CUSTOM AND OFF THE SHELF FURNISHING ZONES ON CAMPUS

CUSTOM FURNISHINGS

Custom furnishings bring dignity to special areas of campus – for example, the custom benches installed in Perelman Plaza. The Plan includes custom furnishings in key areas, including benches with stormwater runnels along Lancaster Walk and curved benches installed under tree canopies on either side of the Walk.

Beyond these special, site-specific pieces, a custom suite of furnishings could clarify the campus identity and provide opportunities for donors to showcase their support for the campus. Durable, long lasting materials and timeless style is crucial when investing in such visible campus elements.



CUSTOM FURNISHING SUITE



SEATING EDGE AND WATER FEATURE ON LANCASTER WALK

OUTDOOR SCULPTURE

Art is a critical component of any campus framework – allowing appreciation of the work itself while also providing focal points and punctuating places of gathering and areas of respite. Henry Mitchell’s “Running Free,” and Moses Jacob Ezekiel’s 1904 sculpture of Anthony J. Drexel are campus landmarks; Eric Berg’s “Mario the Magnificent” marks an important campus meeting place and provides a backdrop to countless campus photographs.

Future outdoor art should be carefully curated and thoughtfully and intentionally placed – to reinforce important intersections, for example, or to complement rain gardens.

The diagram to the right shows the existing sculpture locations and proposed future locations within the new framework plan.



EXAMPLES OF OUTDOOR SCULPTURE

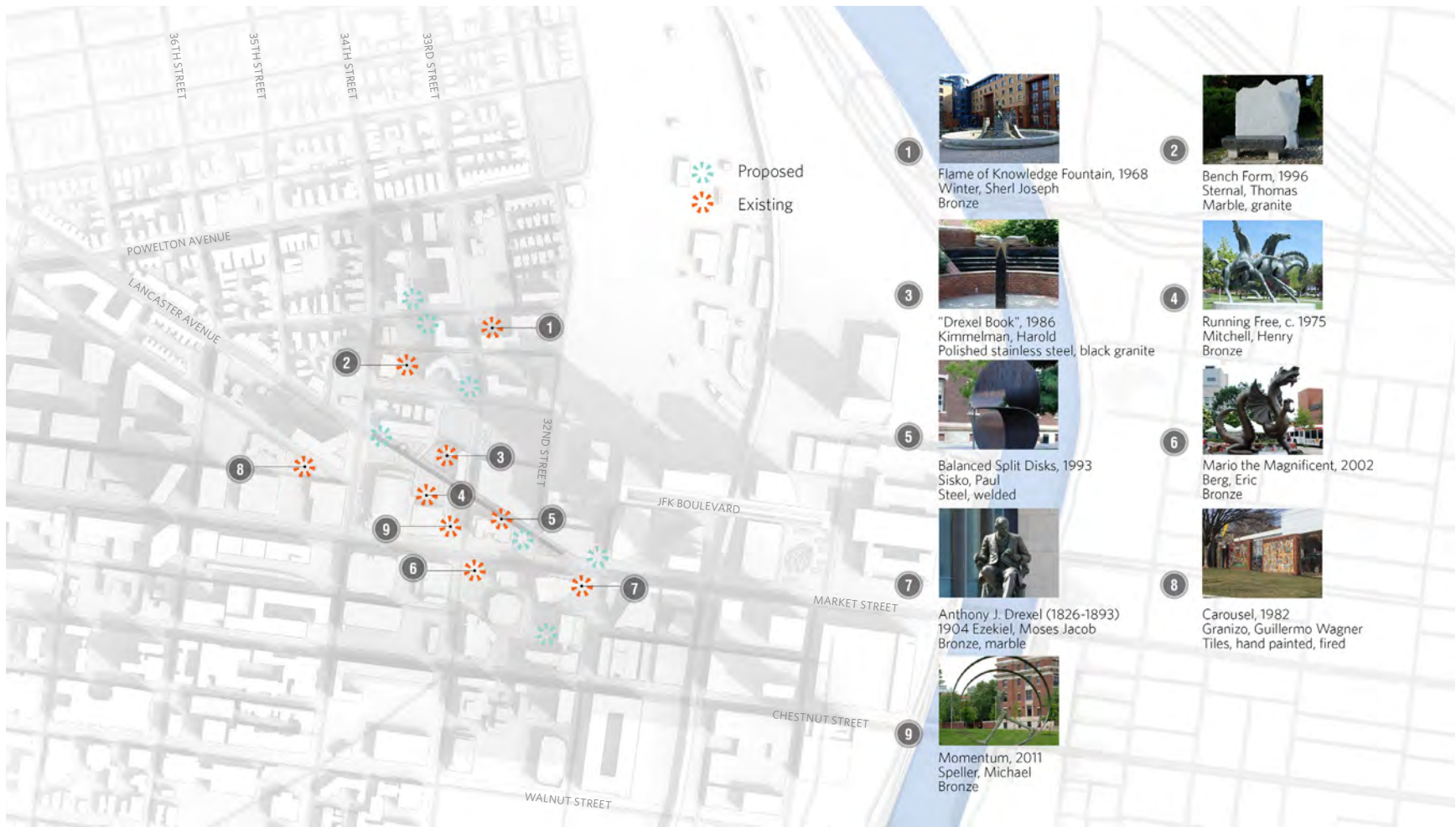

DIAGRAM OF EXISTING AND PROPOSED SCULPTURE LOCATIONS

SERVICE SCREENING

Building servicing is a necessary system which must be managed and designed to have the least amount of visual attention brought to it. Currently, there are several unsightly conditions that are very visible from main streets and sidewalks. An appropriate green screen or planting strategy is needed for each of these areas. To the right, the areas of focus are identified, for their visibility and location on campus.



AREAS TO BE SCREENED ON CAMPUS



DIAGRAM OF AREAS TO BE SCREENED

FOOD TRUCKS

Food culture is important to student life at Drexel, and mobile vending is a popular component of this culture. However, food trucks can be an obstruction in the public realm as they can block views, access, and entrances. Food trucks should be positioned in locations on campus which are accessible by students, faculty, and staff; adjacent to places to sit; and that do not impact negatively important spaces on campus. For example, redeveloping the existing parking lot atop the Design Annex at Cherry and 33rd could simultaneously improve an unattractive space and provide an on-campus locus for mobile vending, should that be desirable. The diagram to the right showcases proposed permanent locations as well as potential event popup locations.



EXAMPLES OF FOOD TRUCKS



DIAGRAM OF SHORT AND LONG TERM FOOD TRUCK LOCATIONS

MATERIALS

The palette of materials on campus should be a coherent and balanced palette of durable, long lasting surfaces, able to withstand the heavy use of university pedestrian and vehicular traffic. Newer projects on campus such as Perelman Plaza and Korman Quad have introduced new materials that work well in terms of durability, identity, and sustainability. These materials should continue to be specified in future projects to develop a consistent language on Drexel's campus. The diagram on the right showcases the opportunities for different palette types based on the identity and use of the public spaces across the campus.

The overall palette builds on the existing palette of light and dark gray paving materials - stone, concrete, and concrete and asphalt pavers. Materials for more casual, park-like areas - the Student Neighborhood and Drexel Park, for example - can include slightly more textured materials within this palette.

PALETTE A

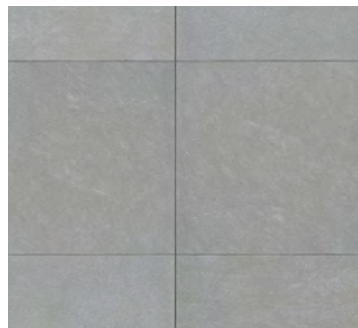

PALETTE B

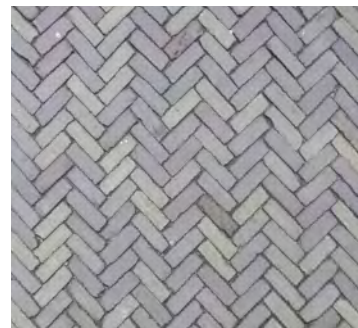

PALETTE C



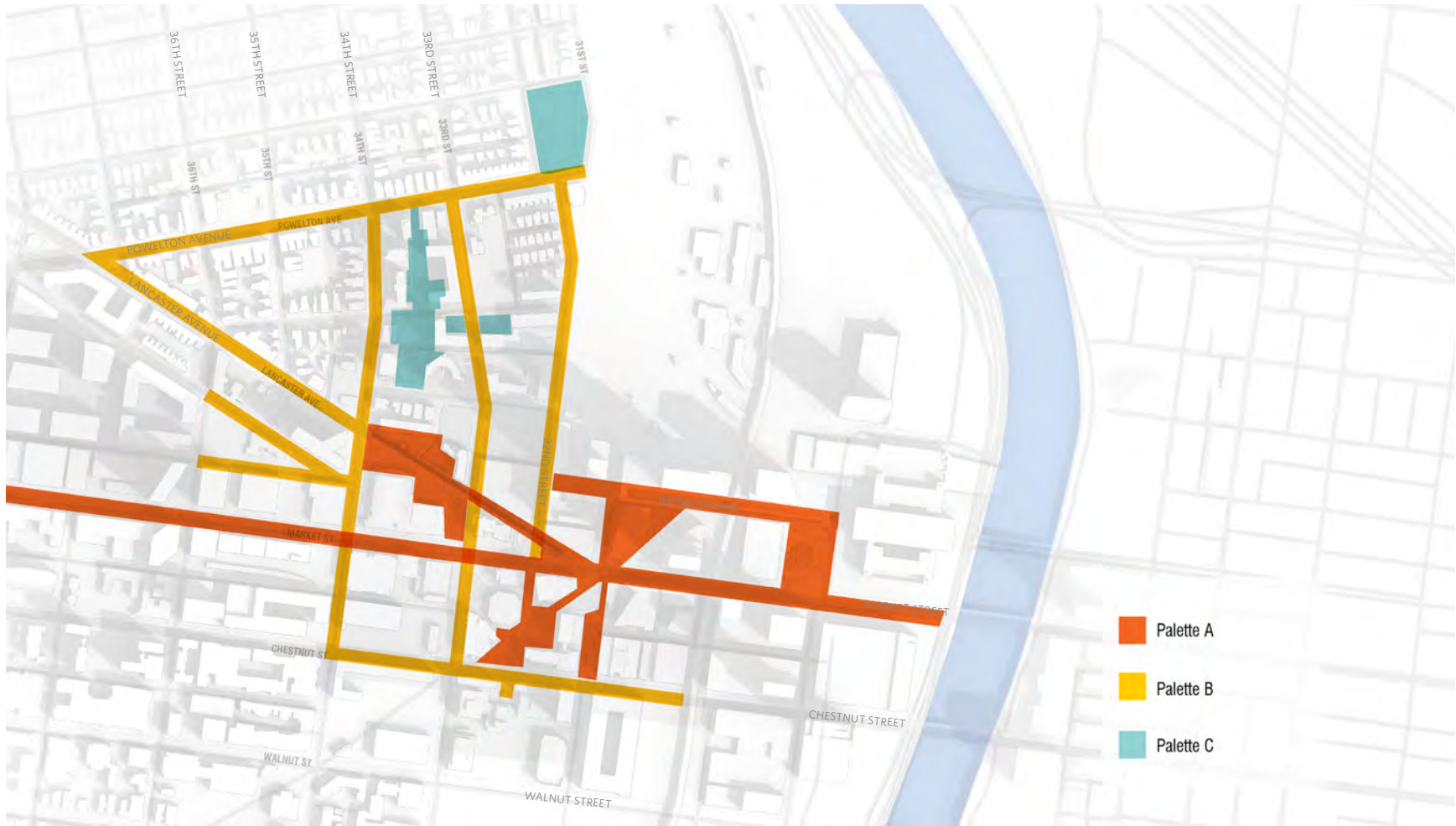

DIAGRAM OF MATERIAL ZONES ON CAMPUS



4

EVENTS AND PROGRAMS

Drexel's campus provides the setting for student life, and includes places for students to spend their time when not in class or at home. The availability, character, and quality of these "third places" are issues of concern for students and for University leaders charged with promoting student engagement in campus life. These places allow the activities that help students develop a connection to their school and begin to feel comfortable with their friends and classmates.

Shared spaces need to be flexible enough to accommodate everyday uses - like hanging out, exercising, eating, studying, outdoor classes, or hosting community events - as well as special activities or rituals like graduation processions or game-night events. Keeping future programming in mind is an essential component of creating successful, multi-use spaces.

Opportunities for informal gathering and more organized programming are integrated into the design concepts for Lancaster Walk and the Student Neighborhood proposed in Chapter 3 of this document. In addition, existing "remnant spaces" identified in Chapter 1 - the seemingly left-over turf areas on campus which do not serve any programmatic or landscape function - are prime opportunity areas for redesign and program development.

OVERVIEW

Because of Drexel's constrained urban location, organizing large events on campus open spaces is challenging. Graduation is held over multiple days or, recently, off site. Certain large scale events are directed elsewhere, and student groups have a difficult time scheduling and organizing events given current campus resources.

With the proposed development of Drexel Square, a new resource would be available for large-scale programming. Proposed improvements to Lancaster Walk and the residential campus would provide additional opportunities for student life to flourish on campus.



PRECEDENT STUDENT EVENTS

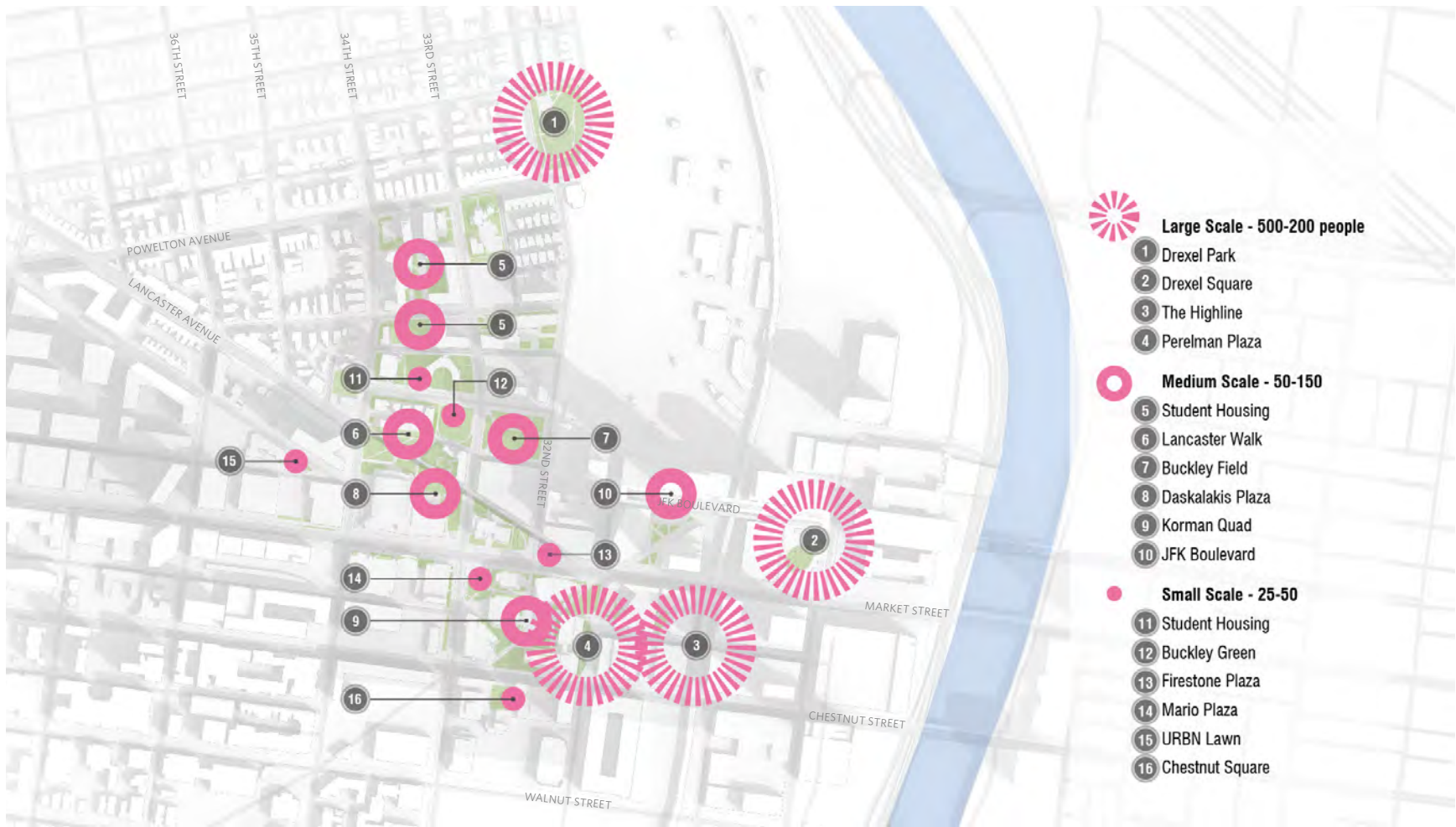

DIAGRAM SHOWING EVENT LOCATIONS ON CAMPUS

SOFT PLAZA + AMPHITHEATER

In addition campus events, space is also needed for campus performances, outdoor classes, and informal discussions. Informal spaces support student life and events by providing impromptu gathering spaces across the campus.



GATHERING LOCATIONS ON CAMPUS





SPORT FIELDS AND FREEPLAY LAWN LOCATIONS ON CAMPUS



SPORTS FIELDS

Organized and free sports are another critical component to campus life. In addition to the Vidas Athletics Complex just west of 42nd Street (about a 25 minute walk from the Mario sculpture at 33rd and Market), Drexel's campus includes well-used opportunities for organized sports at Buckley Green and Buckley Field, and free sports at Drexel Park. Additional opportunities for free sports lawns could be developed within the proposed plans for the student neighborhood and the areas along Lancaster Walk.

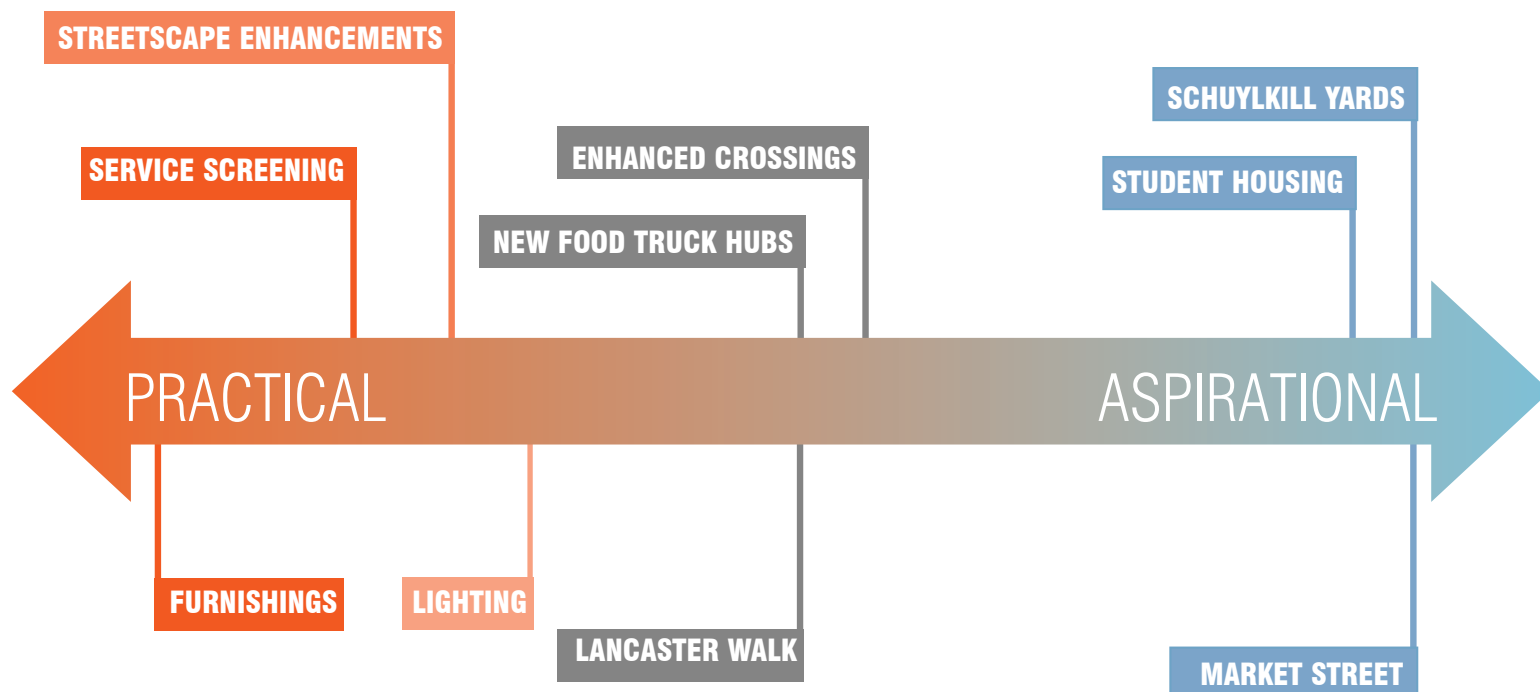

5

NEXT STEPS

This Plan outlines design concepts for transforming areas and systems within Drexel's public realm. Some of these projects would be simple to execute, with relatively modest investment and few required approvals beyond the University. Others, however, would require significant funding as well as additional consultation and buy-in from neighboring residents and organizations, multiple government agencies, and potential funders. For example:

- Editing on-campus site furnishings could be accomplished by Facilities and completed in increments as funding became available.
- Redesigning Lancaster Walk would be transformative, and could be completed relatively quickly - but would require significant dedicated funding.

- Developing Market Street as a green street would add beauty and amenity to the campus experience, and to the gateway between Center City and University City; this would be a complex project involving multiple layers of stakeholders, approvals, and funding sources.

This chapter categorizes projects as:

- Transformational Projects
- Long term projects
- Early Action Projects
- Short term projects with quick results
- Quick Wins
Temporary projects to build support and excitement

TRANSFORMATIONAL PROJECTS

The major projects identified on the right would significantly transform the public realm. These include three site specific investments and a series of campus-wide systems. These have been outlined in previous chapters.

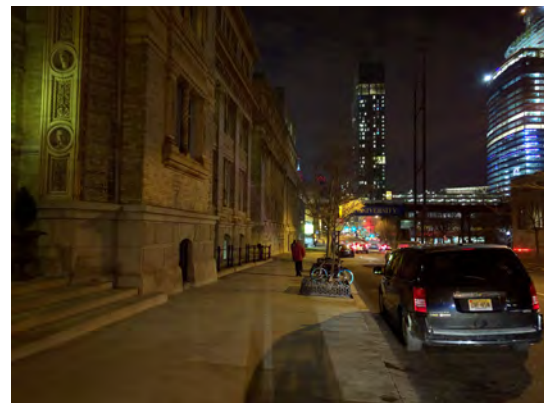

ABOVE: ; THE BEFORE AND AFTER TRANSFORMATION ON MARKET STREET
BELOW: LIGHTING ON CAMPUS SHOULD BE DISTRIBUTED TO CREATE A UNIFORM LIGHT LEVEL

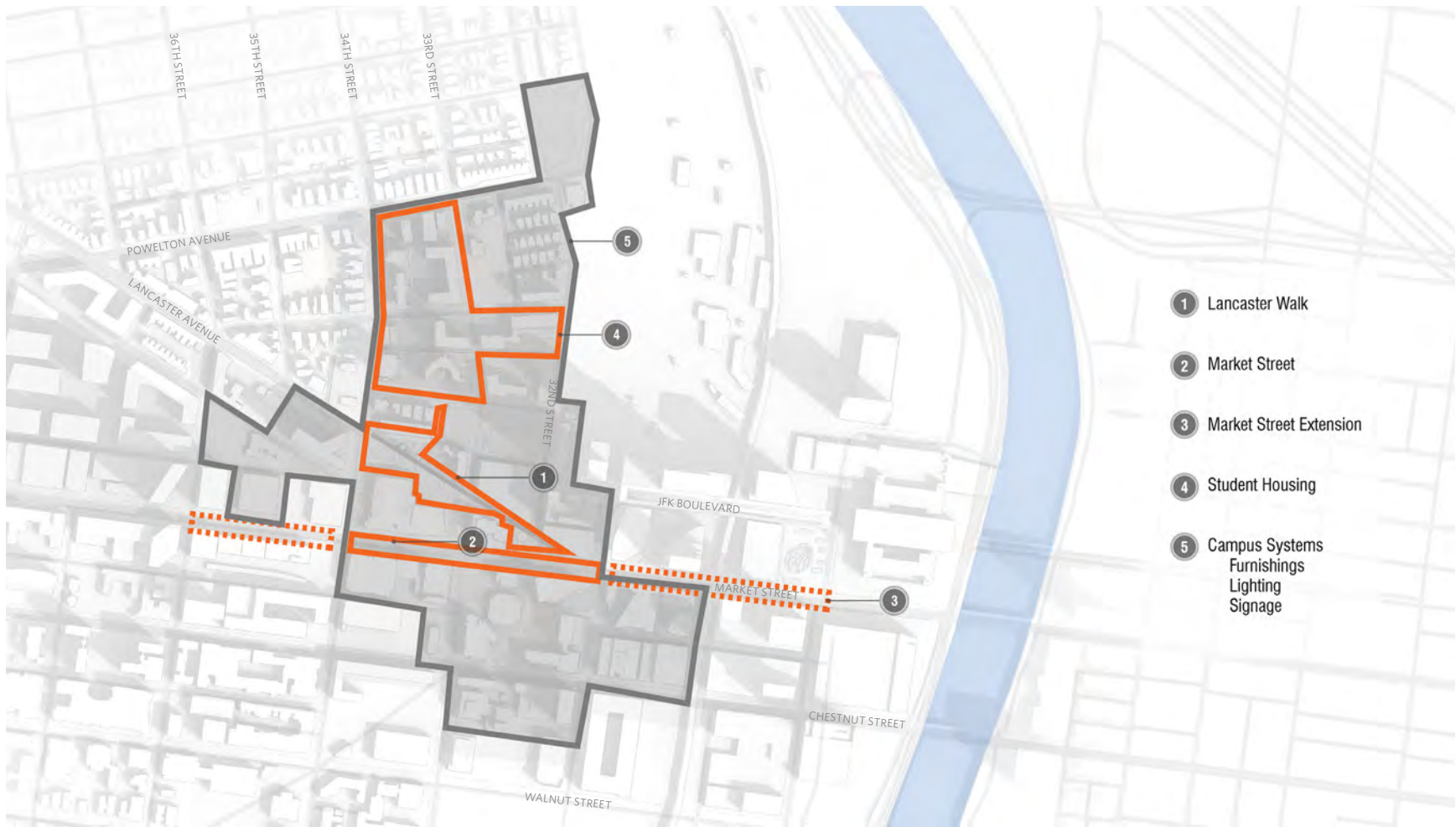

DIAGRAM OF TRANSFORMATIONAL PROJECTS ON CAMPUS

EARLY ACTION PROJECTS

The transformation projects defined in the previous section can be sub divided into smaller projects and installed over a longer period of time.



TOP: LANCASTER WALK RAIN GARDEN
BOTTOM: STUDENT HOUSING QUAD BETWEEN RACE STREET AND CHERRY STREET



DIAGRAM OF EARLY ACTIVATION PROJECTS ON CAMPUS

REMNANT SPACES

The planning team identified many areas on campus as “remnant” spaces – seemingly leftover spaces which do not contribute programmatically to campus life or to a greater campus system. Previous chapters focused on design recommendations for these areas within the context of the greater campus framework.



TOP: EXISTING REMNANT SPACE AT 33RD ST AND RACE ST
BOTTOM: PROPOSED REMNANT SPACE AT 33RD ST AND RACE ST



TOP: EXISTING REMNANT SPACE AT 33RD ST AND CHERRY ST
BOTTOM: PROPOSED REMNANT SPACE AT 33RD ST AND CHERRY ST



DIAGRAM OF REMNANT SPACES ON CAMPUS

QUICK WINS

A number of existing campus locations could be adapted for use for temporary activities, relatively easily and at modest cost. Day- to month-long festivals, furnishings, or mobile food carts could be installed in these spaces to build excitement or gauge interest in a specific University event, program, or amenity.



POPOP ACTIVATION PRECEDENTS

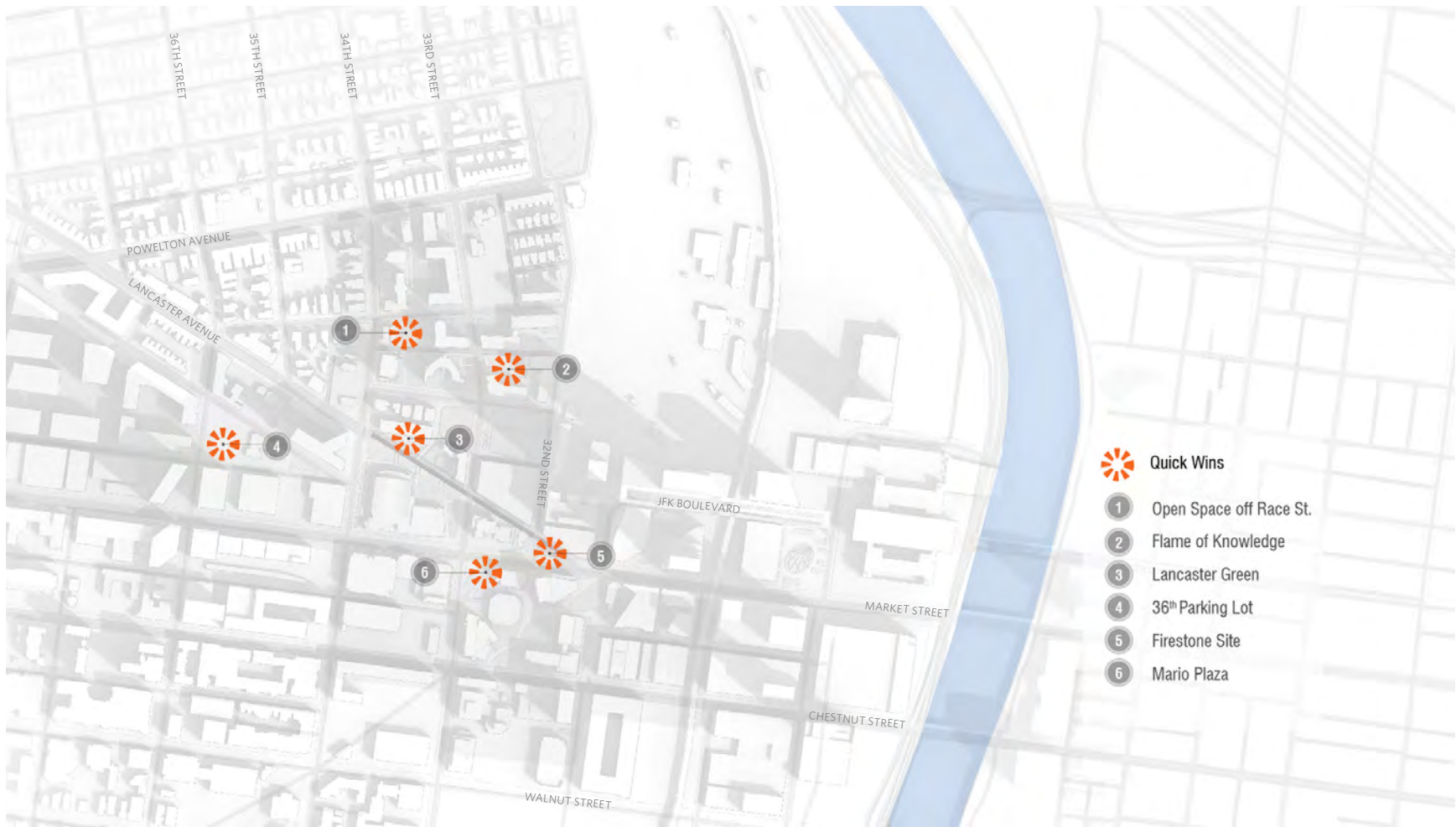

DIAGRAM OF QUICK WINS ON CAMPUS

6

ACKNOWLEDGEMENTS

DESIGN TEAM

West 8	Landscape Architecture and Urban Design
Sam Schwartz	Traffic Engineering
Sitelab	Programming and Architecture
BuroHappold	Sustainability Engineering
Tillotson	Lighting Designer
Pennoni	Stormwater Engineering
Faithful + Gould	Cost Consulting





**PREPARED FOR
DREXEL UNIVERSITY**

DREXEL UNIVERSITY
3141 Chestnut Street
Philadelphia, PA, 19104

PRODUCED BY WEST 8

WEST 8 URBAN DESIGN &
LANDSCAPE ARCHITECTURE P.C.
333 Hudson Street
Suite 905
New York, NY 10013
1: 212 285 0088